



## SYNCHRONOUS MOTOR PROTECTION SYSTEM

Starting protection, synchronization and control for synchronous motors

### KEY BENEFITS

- Complete asset monitoring - Field Winding temperature and statistical data
- Improve uptime of auxiliary equipment - Through I/O monitoring
- Access to information - RS485 Communications port and Modbus RTU Protocol

### APPLICATIONS

- Starting, synchronizing and protection of collector-ring or brushless-type synchronous motors

### FEATURES

#### Protection and Control

- Field application
- DC field current loss, exciter current loss, DC field voltage check
- PF regulation, reluctance torque synchronizing
- Protects motor during start up and in the event of asynchronous operation
- Squirrel cage winding overheating protection
- Automatic phase rotation correction
- Auto-loading and incomplete sequence
- Regulator tuning mode
- True RMS metering with DFT filtering
- Optional power factor regulator with adjustable settings
- Power factor & pull out protection (Optional)
- Speed dependent squirrel cage overload protection
- Motor restart protection

#### Monitoring and Metering

- Motor power factor
- DC exciter amps and voltage
- AC Current
- Exciter field resistance
- Motor run time
- Record of trips

#### User Interface

- 40 Character backlit display for easy viewing of settings and actual values
- Function keys allow programming of settings and viewing of measured values

#### Communications

- RS485 Serial Communications
- Modbus RTU protocol
- Optional Ethernet communications using Multinet Serial to Ether converter

#### EnerVista™ Software

- State of the art software for configuration and commissioning GE Multilin products
- Document and software archiving toolset to ensure reference material and device utilities are up-to-date
- EnerVista™ Integrator providing easy integration of data in the SPM into new or existing monitoring and control systems



## Protection

The SPM controls starting, synchronizing and protection of collector-ring or brushless type synchronous motors.

### Squirrel Cage Protection

An important motor protection function is preventing squirrel cage winding overheating during motor starting. For brushless motors squirrel cage protection is derived from stator current inputs. Protection characteristics are shown in the following graph and the thermal limit is defined by the Stall Time and Locked Rotor Amps relay setpoints.

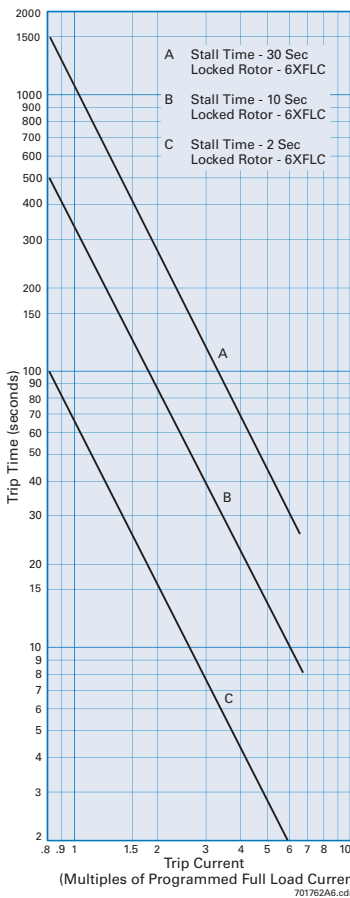

For collector ring motors the squirrel cage protection algorithm is based on motor rotation speed during acceleration. Speed is determined from the frequency of the induced rotor voltage across the rotor discharge resistor.

At less than synchronous speed the following typical cage heating protection characteristics are used:

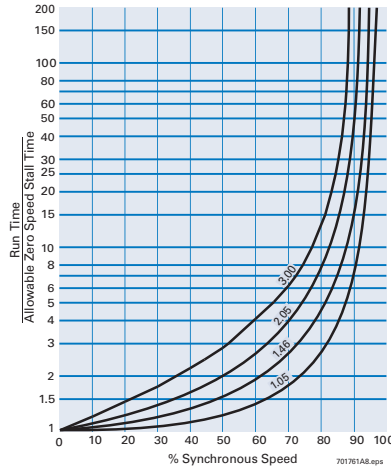

Typical cage heating protection characteristics for collector ring motors.

### Restart Protection

The SPM simulates the cooling of a running motor, updating the relay thermal memory in one-minute spans. The SPM will also learn the amount of thermal capacity required for a successful motor start. Each new value of the thermal capacity is compared with the learned starting capacity required. The SPM will prevent an attempted restart if the cage winding has not had sufficient cooling time to allow a successful start. This element is used to avoid motor overheating due to frequent starts.

### Functional Block Diagram

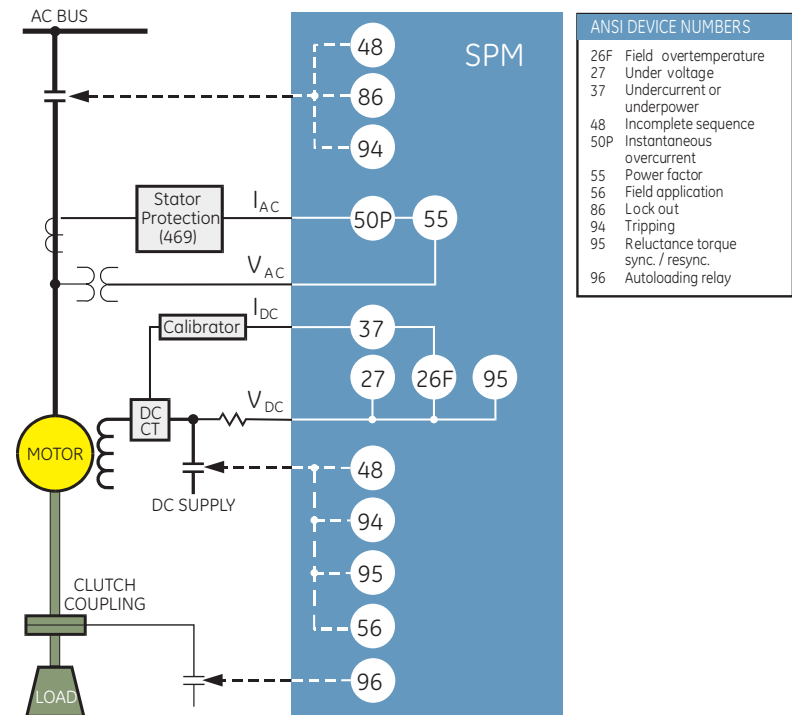

### DC Field Current Loss Protection Option

This feature trips the motor when field current drops below the programmed setpoint after the motor has synchronized. To utilize this feature a DCCT and Field Current Calibration Module must be ordered with the SPM.

### Reduced Voltage Starting

The SPM can dynamically adjust the motor stall time to allow successful starting during reduced voltage conditions.

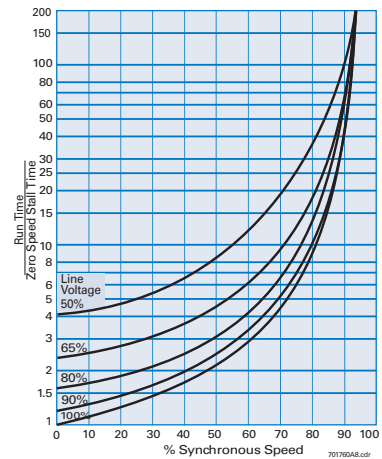

These curves show how the trip characteristic of the amortisseur winding protection is adjusted for reduced voltage starts.

Motor Protection

### Incomplete Sequence Protection

The Incomplete Sequence protection will issue a trip if the SPM detects that the motor has not reached synchronous speed within the programmable time delay.

### Exciter DC Voltage Protection

Exciter voltage protection is available by connecting the exciter output to the SPM terminals VE+ and VE- through a voltage divider network (VDN). This is used on equipment where the exciters are energized prior to motor startup.

### Field Winding Overtemperature Option

This function emulates a resistance temperature device (RTD) on the field windings. As the ratio of field voltage to field current increases, the field resistance increases, indicating an increase in temperature of the field winding. Field Winding Overtemperature is only available when the optional DCCT and Field Current Calibration Module have been ordered with the SPM.

## Control Features

The SPM offers users advanced control features such as:

### Power Factor (Pull-Out) Protection

The SPM provides pull-out protection for synchronous motors operating in either generating or motoring modes. The SPM provides power factor settings and displays the measured leading/lagging power factor. The power factor regulation option enables field forcing in advance of a pull-out condition. Motor pull-out protection is provided by a circuit which monitors the power factor and has a built in time delay to prevent inadvertent tripping on transients. Two modes of pull-out protection are available, re-sync mode and ride-thru mode. These modes will be initiated if the lagging power factor drops below the programmed set point, or if a line current surge occurs which is above four times the motor full load current. Re-sync mode operation will cause the Field Application Relay (FAR) to remove the motor field excitation. The motor will continue to run with the field removed for the programmed power factor delay time.

If re-synchronization does not occur within this time the trip relay will operate and the motor will stop.

In ride-thru mode the motor field excitation is not removed immediately. Instead, the SPM allows the motor to run for the power factor delay time. If the power factor dip or line current surge persists, the trip relay will operate and the motor will stop.

### Starting and Synchronizing

For collector ring motors, the SPM detects the rotor speed and angle and determines the correct time to close the field application relay based on the percent synchronous slip setpoint. This applies excitation to the motor field and opens up the field discharge resistor loop.

For brushless motors, the voltage is applied to the exciter after a preset programmable time elapses. Power factor pullout protection is then enabled. A contact (FCX) is also provided to signal automatic motor loading.

### Reluctance Torque Synchronizing

Reluctance torque synchronizing is when a lightly loaded synchronous motor pulls into synchronization before the rotor poles are externally magnetized. The SPM's field application control responds by applying excitation if a motor synchronizes on reluctance torque.

### Power Factor Regulation

Power factor regulation is a DC control signal output used to control a variable SCR exciter output. This replaces the standard power factor analog signal output. This option is not recommended for brushless applications. The regulator has five set-points that can be adjusted while the motor is running to facilitate regulator tune-up. They are:

- PF setpoint – range from 0.9 lagging, through 1.0 to 0.0 leading
- Reg output – upper limit of the control voltage output signal
- Reg gain – adjusted for optimum regulator performance
- Reg stability – time adjustment to help compensate for instability
- Reg floor – lower limit of the control voltage output signal

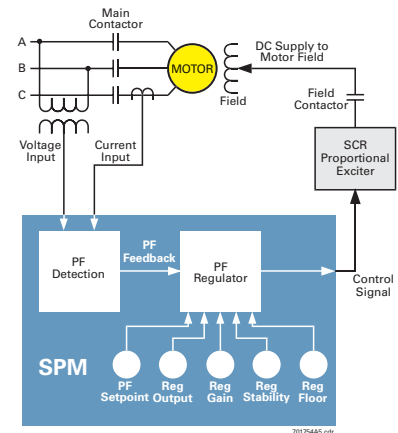

Power factor regulation – functional block diagram.

## Monitoring and Metering

The SPM provides a number of monitoring and metering functions including:

### SPM Displays and Messages

The SPM has a 40 character LCD display for programming, displaying trip information, and monitoring metered values such as line amperes, field amperes, power factor, line current, field volts, field current, and field ohms. The SPM also stores motor run time and the number and types of motor trips. Trip, Field Application (FAR) and FCX relay states may also be monitored.

### Self-Tests and Diagnostics

The SPM has built-in test diagnostics to indicate that the relay is operating properly prior to start-up. The SPM also contains a test mode, which includes the following tests:

- Trip relay contacts
- System test
- Squirrel cage protection test
- Synchronization
- Power factor test

The system test performs a complete check of the internal memory, input-output devices and other system functions.

## Inputs and Outputs

The SPM offers the user a variety of input and output solutions:

**Field Voltage Input:**

The induced field voltages VF+ and VF- are monitored through their connection to the external discharge resistor via the VDN, providing instantaneous value of motor slip.

**Exciter Voltage Input:**

The VE+ and VE- terminals are connected to the exciter via the VDN to monitor DC exciter voltage.

**Exciter Current Input:**

The field current IE+ and IE- terminals are connected to the DC field via a DCCT and a calibration module (ordered separately) to detect field loss.

**Motor Line Current:**

Two input terminals, or four for brushless, are connected to the system current transformers.

**Motor 'On' Input:**

Accepts a normally closed dry electrical interlock that opens when the motor is energized and closes when the motor is de-energized.

Reduced Voltage Starting Input: Accepts a normally open dry electrical interlock that

closes when the motor reaches full voltage during a reduced inrush start.

Control Power: The SPM has an AC power supply with a range from 85 to 265 VAC. If control voltage excursions occur outside this range, an external stabilizing ansformer should be used in conjunction with optional separate power factor reference voltage inputs.

**Power Factor Reference Voltage:**

The PF reference voltage is derived from the control power terminals, V1 and V2. The SPM also has an optional input for separately powered PF reference voltage, V1EXT and V2EXT. Effective range 85 to 265 VAC.

**Power Factor Analog Signal Output:**

A zero to ten volt DC output corresponds to the motor power factor. Zero volts represents zero lagging power factor, five volts represents unity power factor, and ten volts represents zero leading power factor. A one volt change corresponds to an 18 degree phase shift.

**Power Factor Control Signal:**

If the relay is furnished with the power factor regulation option, then the Power Factor

Analog Output is replaced with a 0 to 10 V power factor regulation control output. This signal is used as an input to a variable SCR exciter.

**Trip Relay:**

The Trip contact is connected to a failsafe normally open contact. This contact closes on relay power up and opens on a trip condition to de-energize the motor.

**FAR Relay:**

The field application relay is a normally open contact. This contact closes to apply DC to the motor field to pull motor into synchronization.

**FCX Relay:**

The field contactor auxiliary relay picks up at setpoint time delay after the FAR relay picks up and is used to signal external systems to auto load/unload the motor.

**Communications**

The SPM is equipped with a rear RS485 port that can be used for remote programming, or for connection to a DCS, SCADA, or PLC. The port supports ModBus® RTU protocol. The RS485 port baud rate is variable from 300-115,000 bps.

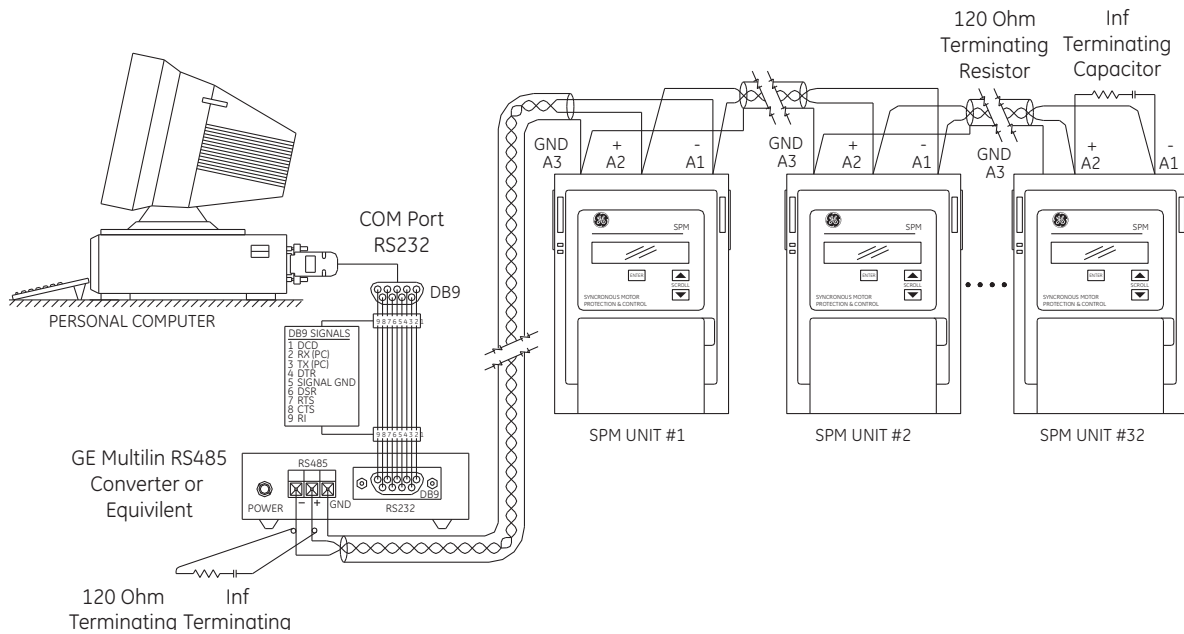

## EnerVista™ Software

The EnerVista™ Suite is an industry leading set of software programs that will simplify every aspect of using the SPM relay. Tools to monitor the status of your motor, maintain your relay, and integrate information measured by the SPM into HMI or SCADA monitoring systems are available.

### EnerVista™ Launchpad

EnerVista™ Launchpad is a powerful software package that provides users with all of the setup and support tools needed for configuring and maintaining GE Multilin products. Launchpad allows configuring devices in real-time by communicating using serial, Ethernet, or

modem connections, or offline by creating setting files to be sent to devices at a later time. Included in Launchpad is a document archiving and management system that ensures critical documentation is up-to-date and available when needed. Documents made available include:

- Manuals
- Application Notes
- Guideform Specifications
- Brochures
- Wiring Diagrams
- FAQ's
- Service Bulletins

### Viewpoint Monitoring

Viewpoint Monitoring is a powerful yet

simple-to-use monitoring and data recording of small systems. Viewpoint Monitoring provides a complete HMI package with the following functionality:

- Plug-&-Play Device Monitoring
- Single-Line Monitoring & Control
- Annunciator Alarming
- Trending Reports

### EnerVista™ Integrator

EnerVista™ Integrator is a toolkit that allows seamless integration of GE Multilin devices into new or existing automation systems. Included in EnerVista Integrator is:

- OPC/DDE Server
- GE Multilin Drivers

## Hardware

### Space Saving Case

The SPM is supplied in a compact S1 drawout case. The drawout case allows the unit to be removed without disconnecting the rear terminal wiring.

### Voltage Divider Network (VDN)

The VDN is provided to connect the SPM to field and/or exciter voltages.

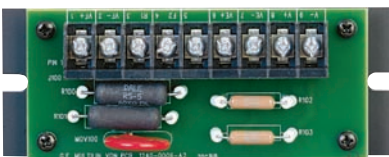

The VDN is included as a standard accessory.

### Calibration Module (CM)

This optional accessory provides proper AC excitation to the DCCT and provides calibration adjustment to obtain correct field amp readings. The CM is required for field current and/or field overtemperature features.



The CM calibration module is included with the optional PG2SPM or PG4SPM overtemperature/current loss accessory package.

### DC Current Transformer (DCCT)

The optional DCCT detects DC field current. The DCCT is required for field current and/or field overtemperature features. 200A and 400A versions are available. The DCCT



works in conjunction with the CM and both are available in a separate accessory package. See order code for more details.

DCCT is included with the optional PG2SPM or PG4SPM overtemperature/current loss accessory package.



## Typical Wiring

### NOMENCLATURE

CM	FIELD CURRENT CALIBRATION MODULE
DCCT	DIRECT CURRENT CT
M	MAIN CONTACTOR
OL	OVERLOAD RELAY
T1, T2, T3	MOTOR TERMINALS
	OPTIONAL ACCESSORIES

### NOTES:

- 1) Relays shown with no control power applied to relay
- 2) \*Trip Relay closed during normal operation

### TYPICAL BRUSHLESS MOTOR CONNECTION

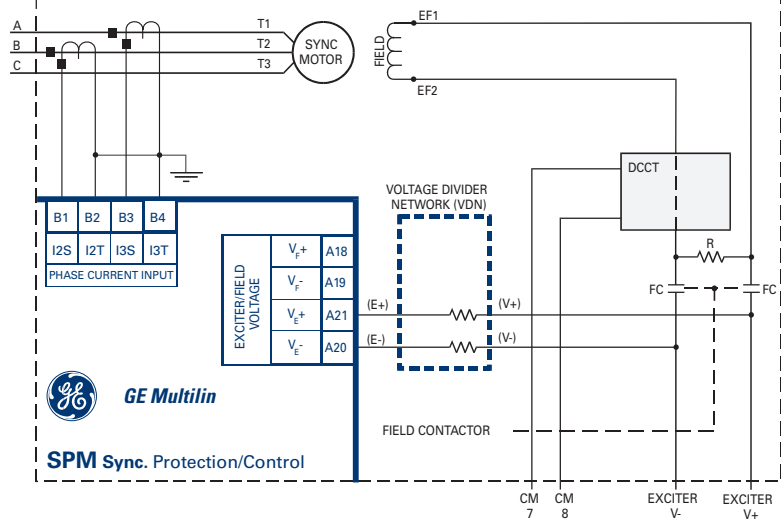

### TYPICAL COLLECTOR RING MOTOR CONNECTION

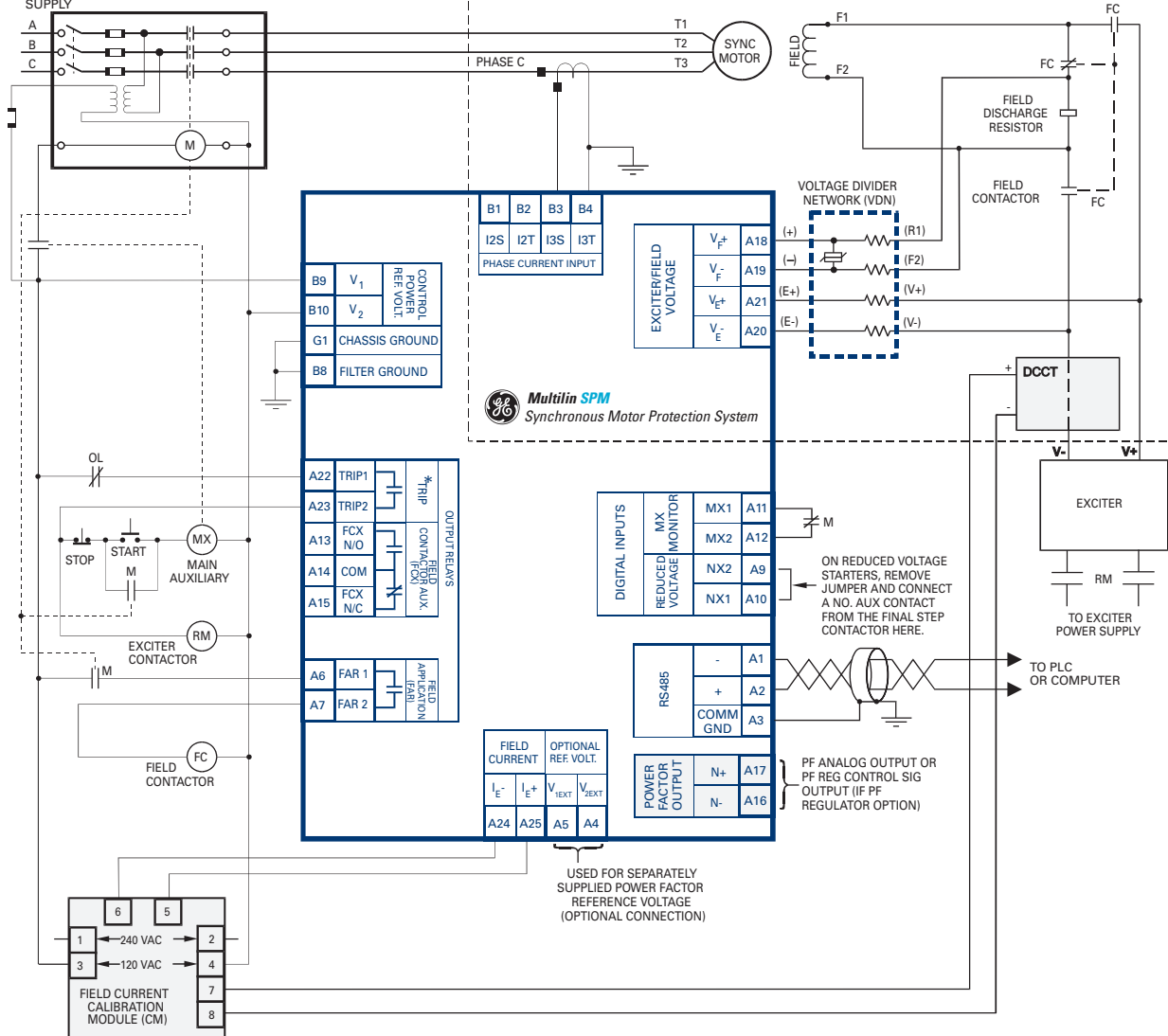

Motor Protection

## Features

### Front View

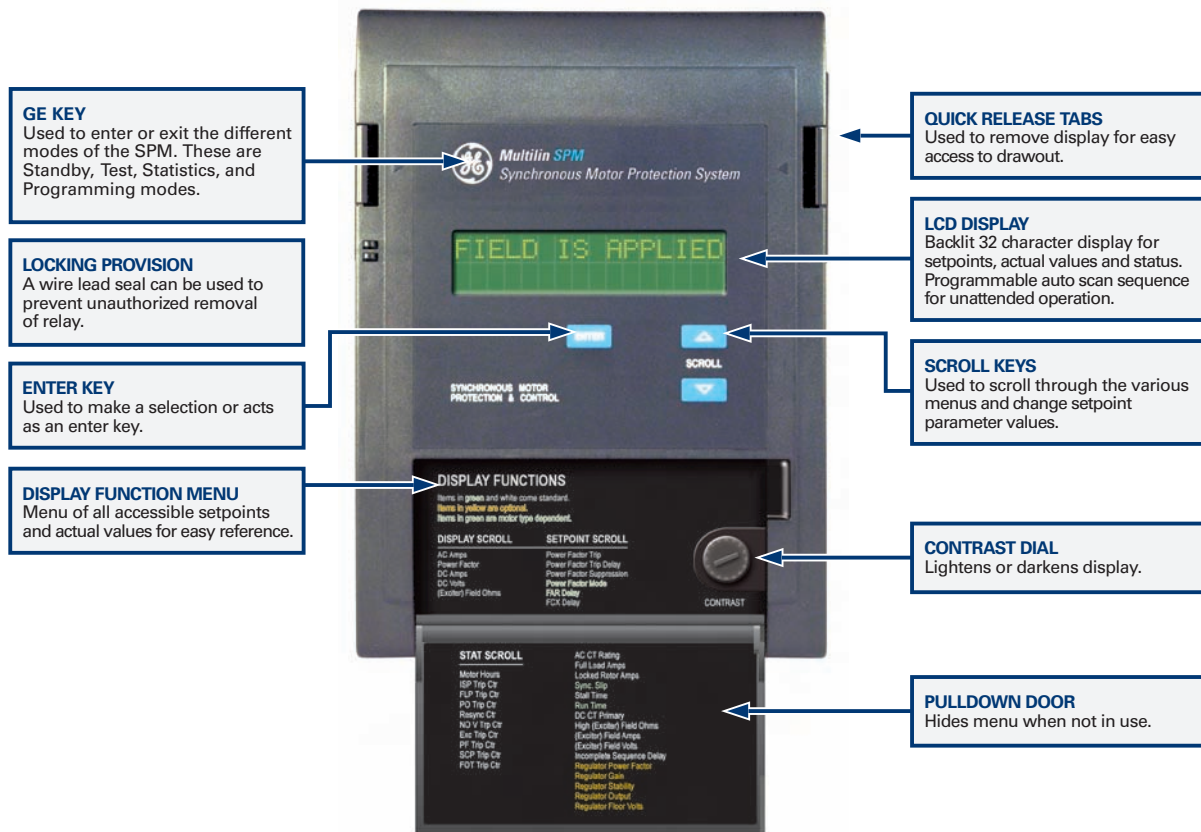

### Rear View

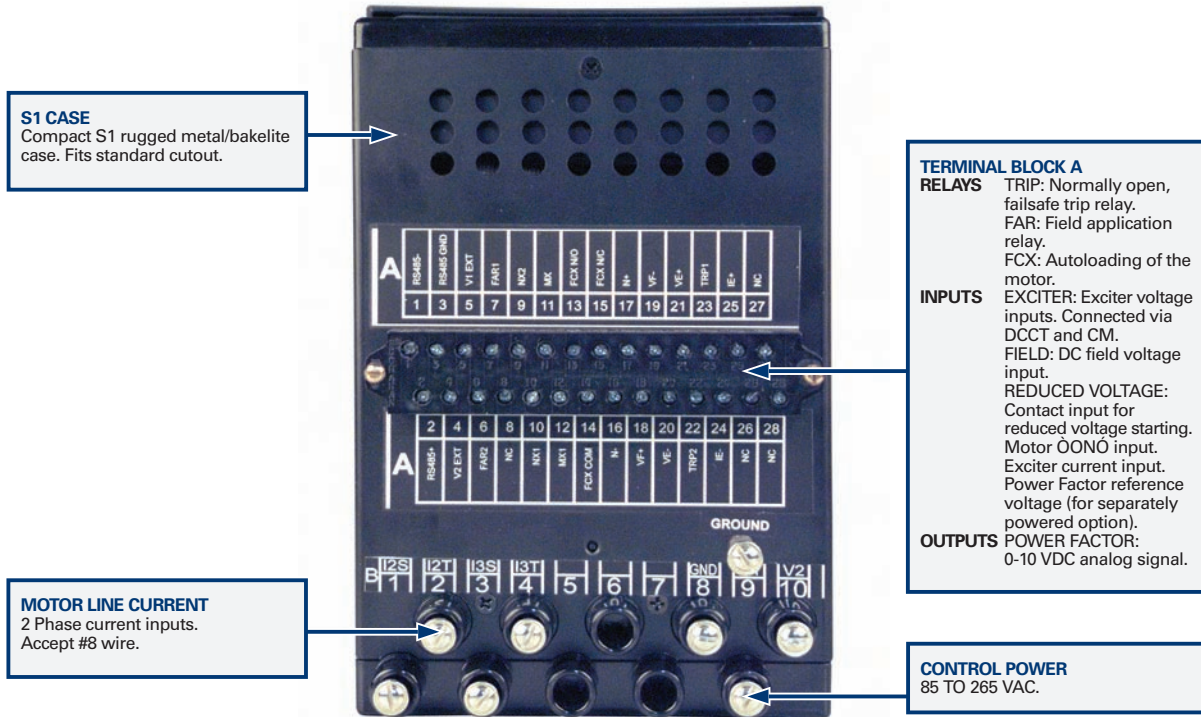

## Technical Specifications

### METERING

#### PHASE CURRENT INPUTS

CT primary: 5 – 2000  
 CT secondary: 5  
 Conversion range: 0.05 – 6 x CT  
 Frequency: 50/60 Hz  
 Accuracy: @ <2 x CT ±0.5% of 2 x CT true RMS  
 @ <2 x CT ±1% of 6 x CT true RMS

### MONITORING

#### POWER FACTOR

Range: 0.01 to 1 to -0.01  
 Time delay: 0.1 – 10 sec  
 Accuracy: ±5%

### INPUTS

#### FIELD CURRENT INPUTS

CT primary: 5 – 1000  
 Conversion range: 0.05 – 1 x CT  
 Accuracy: ± 2%

#### EXCITER VOLTAGE INPUTS

Conversion: 0 – 350 VDC (prior to VDN)  
 Accuracy: ±1%

#### SWITCH INPUTS (MX AND NX)

Type: Dry contact  
 Internal interrogation voltage: 85 – 265 VAC (control voltage)

### OUTPUTS

#### PF ANALOG OUTPUT

Type: Active  
 Output: 0 – 10 VDC max @ RL 1K (min load)  
 Accuracy: ±10% (0.1 v)  
 Isolation: 36 V Vpk

#### RELAY CONTACTS

Type: FAR, TRP Form A  
 FCX Form C

#### Rated load:

10 A AC continuous NEMA A300  
 1 A DC continuous NEMA R300  
 10A 250 VAC or 30 VDC

#### Break:

Max operating voltage: 250 VAC

### POWER SUPPLY

#### CONTROL POWER

Input: 85 – 265 VAC @ 48 – 60 Hz  
 Power: 10 VA nominal  
 Holdup: 100 ms typical @ 120 VAC

### ENVIRONMENTAL

Humidity: 0 – 95% non-condensing  
 Operating temperature: -20° C to +70° C  
 Storage temperature: -40° C to +85° C

### PACKAGING

Shipping box: 12.50" x 10.50" x 9.75" (L x H x D)  
 318 mm x 267 mm x 248 mm (L x H x D)  
 Ship weight: 14.25 lbs/6.45 kg

### APPROVALS

UL: UL listed  
 CSA: CSA approved

### TYPE TESTS

**Dielectric strength:** Per IEC 255-5 and ANSI/IEEE C37.90, 2.0 kV for 1 minute from relays, CTs, VTs power supply to safety ground

**Insulation resistance:** IEC255-5 500 VDC, from relays, CTs, VTs, power supply to safety ground  
 ANSI C37.90.1 oscillatory (2.5 kV/1 MHz)  
 ANSI C37.90.1 fast rise (5 kV/10 ns Ontario Hydro A-28M-82  
 IEC255-4 impulse/high frequency disturbance, Class III Level  
 IEC 255-5 0.5 Joule 5 kV  
 C37.90.2 electromagnetic interference @ 150 MHz and 450 MHz, 10 V/m

**Static:** IEC 801-2 static discharge  
**Vibration:** Sinusoidal vibration 8.0 g for 72 hrs

\*Specifications subject to change without notice.

## Dimensions

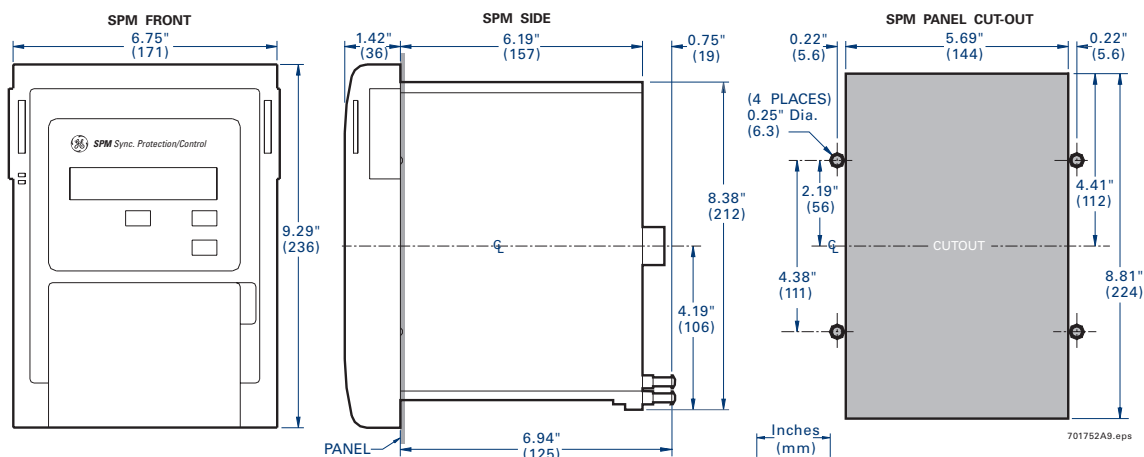

## Ordering

SPM	*	*	SPM: standard starting and protection relay with VDN board PF: power factor regulation option used on motors with proportional SCR exciter. (not recommended for brushless applications) H: Harsh environment conformal coating
SPM	PF		
		H	

### Accessories for the SPM

- 200A DCCT & Calibration Module PG2SPM
- 400A DCCT & Calibration Module PG4SPM
- µSPM Retrofit Package MPSPM
- Viewpoint Monitoring VP-1

### Visit [www.GEMultilin.com/SPM](http://www.GEMultilin.com/SPM) to:



- View Guideform specifications
- Download the instruction manual
- Review applications notes and support documents
- Buy an SPM online