

BA300

Substation Battery Monitoring

Many substation battery installations are not only required to provide a DC supply for protection and control equipment, but also to provide trip and close currents to breakers during trip conditions.

BA300 monitoring the performance of the DC system is fundamental to the safe, reliable and efficient operation of the substation. BA300 monitors DC auxiliary supply to ensure electrical equipment integrity by:

- Ensuring efficient operation of substation equipment
- Monitoring battery condition and ability to provide trip and closing current to circuit breakers
- Allowing effective maintenance strategies to ensure security of system operation

Application

For substations it is important that the security of supply is maintained. This means not only that the battery voltage is within required limits, but that each leakage and any latent faults in the battery and its connections will not result in failure to initiate tripping when a heavy current is demanded.

BA300 has been designed specifically for electrical substation batteries and has become a standard for many utilities both for new installations and retrofit to existing batteries. It is suitable for all batteries with an internal impedance exceeding 0.1 Ohm.

For battery charger systems fitted with capacitor filtered outputs, the battery alarm requires a choke of 0.5 mH to be fitted at the output of the charger to ensure correct operation of the high impedance alarm.

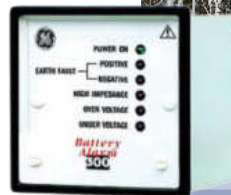

Comprehensive Functionalities

BA300 is designed to provide comprehensive continual battery monitoring and alarm indication for:

- Over and under voltage conditions
- High impedance alarm
- Earth fault alarm
- Battery ability to provide load current
- Battery in service monitoring

Key Benefits

- Monitors critical DC operated systems
- Ensures battery charger is operating correctly
- Alarms when battery circuit impedance exceeds safe operating levels



Description

Mounting

The BA300 is designed for flush panel mounting and connection to the battery bus wiring. This forms the source of supply for the electronics and enables the BA300 to monitor the battery performance.

Output Relays

The outputs provided are volt free contacts from two separate relays, URGENT and NON URGENT.

URGENT is normally energised and will de-energise if the monitored parameters deviate beyond preset limits.

NON URGENT is normally de-energised and will energise if the monitored parameters deviate beyond preset limits.

Each relay channel is fitted with a preset timer which serves to inhibit alarms of a transient nature. In addition, each relay can also be configured to monitor any, or all, of the battery parameters. Two sets of changeover contacts are available on each relay.

A version is available with both relays designated as NON URGENT, where the relays are normally de-energised.

High Impedance Alarm

The high impedance alarm circuit monitors the ability of the battery, together with the charger and associated wiring, to provide a heavy current pulse.

The impedance monitoring circuit operates by drawing a series of heavy current pulses (approx 1A) from the battery busbars. The values of these pulses are stored and, if a succession of pulses is low, the alarm will operate. The circuit is driven by a low frequency oscillator which gives a pulse rate of two per second with a pulse duration of about 50 microseconds.

The high impedance monitoring circuit can be adjusted to monitor battery impedances in the range of 0.1 W to 5 W.

It should be noted that the resistance of the fuses and connecting cable has an effect on the potentiometer setting. Fuses should be rated at 2A and all wiring to the battery alarm should be kept as short and direct as possible.

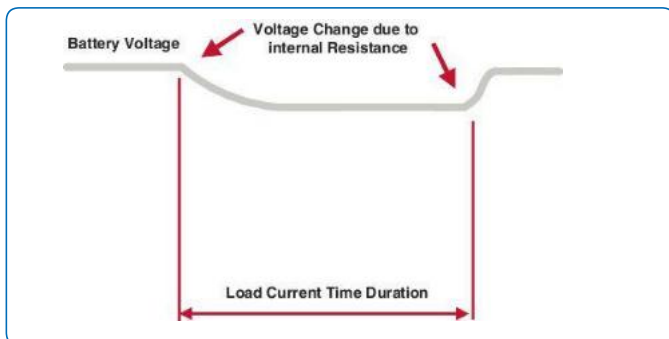

Effect of internal resistance

Voltage Alarm Level Setting

The voltage levels specified will depend on the operating conditions of the battery installation and the purpose for which the alarms are required. However, the working range of the BA300 must be taken into account when deciding on a specification.

The BA300 power supply can accommodate a maximum variation of 80% to 140% in the nominal voltage from the battery.

The power supply is generally designed to operate over a voltage range from the maximum boost voltage to the minimum voltage below which a battery would not normally be allowed to deteriorate. The over and under voltage alarm settings must be within this range.

The table below can be used as a guide to suitable settings:

Parameter (per cell)	Lead Acid	Alkaline
Nominal volts	2.00	1.20
Max volts on boost	2.60	1.68
Working volts on charge	2.27	1.46
Minimum volts	1.85	1.00
Low alarm operation	2.14	1.32
High alarm operation	2.40	1.52

For example a 55 cell lead acid battery
 Low alarm setting = $55 \times 2.14 = 117.7 \text{ V}$
 High alarm setting = $55 \times 2.40 = 132 \text{ V}$

NOTE : the under and over voltage alarms have built in hysteresis to prevent contact chatter. This hysteresis (or pick up/ drop off differential) will result in a high alarm reset voltage of $[0.995 \times V_{trip}] \pm 0.5\%$ and a low alarm reset voltage of $[1.005 \times V_{trip}] \pm 0.5\%$.

High Voltage Cut-off Facility

A high voltage cut off facility is achieved by routing the over voltage alarm through the NON URGENT alarm with a short time delay of about 2 seconds and also through the URGENT alarm with a longer time delay of about 50 seconds.

This provides a means of switching off the charger or performing other switching operations on detection of a high voltage alarm condition.

A similar low voltage cut off version can also be provided.

EARTH FAULT ALARM

The earth terminal on the BA300 is connected to the case back plate and also to the earth fault circuit input.

A leakage path from either the positive or negative pole of the battery to earth will cause a current to flow in the input to the earth fault circuit. If this current exceeds a predetermined value, the earth fault relay will operate and the relevant LED will illuminate.

The earth fault trip level is preset in the range 5 to 90 k and is symmetrical for both positive and negative earth faults, irrespective of the battery voltage.

If either the positive or negative of the battery is earthed, the BA300 will indicate an earth fault alarm. Where an earth fault relay is already fitted, it is recommended that the BA300 is supplied without the earth fault function.

Alarm Indication and Relay Outputs

A popular configuration for alarm relay outputs is:

- URGENT alarm for over voltage, under voltage and high impedance
- NON-URGENT alarm for earth faults

On detection of an over voltage, under voltage or high impedance fault, the associated alarm LED will light immediately. At this stage the urgent alarm delay will start to time out and, if the fault persists, the urgent alarm relay will release after the delay time.

On detection of an earth fault, the associated alarm led will light and the NON-URGENT delay timer (usually 1 s for earth faults) will start. The NONURGENT relay will pickup when the timer times-out. Each relay channel is fitted with a timer and each channel can be configured to monitor any of the battery parameters. Both relays have two sets of voltfree changeover contacts which can be used for local and remote alarms, SCADA inputs etc.

Alarm	Contact	Terminal
NON URGENT	NO	3
	COM	1
	NC	2
	NO	6
	COM	4
	NC	5
URGENT	NO	8
	COM	7
	NC	9
	NO	11
	COM	10
	NC	12

Fail to Safety and Power on Reset or Urgent Alarm Relay

If the supply voltage falls below 66% V_b for longer than 50 ms, an instantaneous URGENT alarm is given. When the supply voltage returns to above 66% V_b, a power on reset occurs after a time delay of 1 second.

External Chokes

A 0.5 Mh DC choke should be fitted when the battery charger has capacitor filtered output.

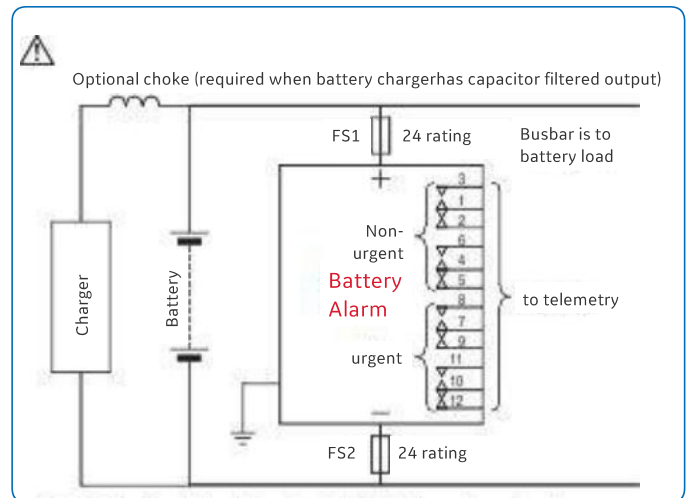

BA300 connection to the battery circuit

Note: The battery alarm is shown in the energised state. Under healthy operating conditions, the urgent relay is operated and the non-urgent relay is released.

Susceptibility to Electrostatic

Discharge 8 kV air discharge/4 kV contact.

Warning

This specification applies when the front cover is fitted. If the front cover is removed to gain access to the adjustment potentiometers then appropriate ESD protection must be taken.

Technical Specifications

Battery Information

Battery Voltages (Vb)	24, 30, 32, 48, 50, 60, 110, 125 (220 Vdc)
Operating range	80% to 140% Vb
Burden	20 mA nominal
Voltage alarm levels (adjustable)	
- Under voltage range	80% to 110% Vb
- Over voltage range	105% to 140% Vb
- Accuracy of settings	+/- 0.5
- Hysteresis on setting	0.5%
Earth leakage protection (preset)	
- Trip level range	5 k Ω to 90 k Ω
- Accuracy of trip level	+/- 10%
- Hysteresis on trip level	5%
- Short circuit current	<5 mA
High impedance alarm (adjustable)	
- Setting range	0.1 Ω to 5.0 Ω
- Accuracy of settings	+/- 0.05 Ω
Battery Voltages (Vb)	24, 30, 32, 48, 50, 60, 110, 125 (220 Vdc)

Temperature

Nominal range of use	
- Reference temperature	+23°C
Temperature coefficient	
- Voltage alarms	+/- 0.006% / °C
- Earth leakage alarms	+/- 0.06% / °C
- Timer settings	+/- 0.06% / °C
- High impedance alarm	<0.1 Ω deviation in setting over temperature range

Timers

Alarm time delay settings	
- Accuracy of setting	+/- 10% (60.25 s)

Output Relays

URGENT alarm relay	2 changeover contacts
NON-URGENT alarm relay	2 changeover contacts

Contact Ratings

Max. switching power	60 W, 62.5 VA
Max. switching voltage	220 Vdc, 250 Vac
Max. switching current	2 A
Max. carrying current	3 A
Isolation	750 Vrms across open contacts
URGENT alarm relay	2 changeover contacts

LED Indication

Power on	Green LED
Earth fault positive	Red LED
Earth fault negative	Red LED
High impedance	Red LED
Over voltage	Red LED
Under voltage	Red LED

Miscellaneous

Series mode noise (ripple)	10% Vb (pk-pk) 50 to 120 Hz
Common mode noise	Series mode noise (ripple)
Isolation	1 kVrms between inputs and alarm contacts
Impulse	5 kV (1.2/50 μ s) to IEC60060-1 and IEC60255-5/ BS5992-3
High frequency disturbance	To IEC60255-22-1 / BS142 section 1.5.1
Overload rating	2 x Vb continuous or 200 Vdc whichever is lower
220 V version	350 Vdc continuous
Humidity	0 to 93%, +2%, -3% RH
Terminals	Barrier type M3.5

For more information please contact
GE
Grid Solutions

Worldwide Contact Center

Web: www.GEGridSolutions.com/contact
Phone: +44 (0) 1785 250 070

GEGridSolutions.com

IEC is a registered trademark of Commission Electrotechnique Internationale. IEEE is a registered trademark of the Institute of Electrical Electronics Engineers, Inc.

GE and the GE monogram are trademarks of General Electric Company.

GE reserves the right to make changes to specifications of products described at any time without notice and without obligation to notify any person of such changes.

BA300-Brochure-EN-2018-12-Grid-GA-0776. © Copyright 2018, General Electric Company. All rights reserved.



Imagination at work