

GE
Grid Solutions

DR60

Digital Recorder



Technical Manual

Platform Hardware Version: A

Platform Software Version: 2

Publication Reference: DR60-TM-EN-2.7A



imagination at work

Contents

Chapter 1: Introduction		7
1	Foreword	7
1.1	Target Audience	7
1.2	Nomenclature	7
1.3	Abbreviations	8
2	Product Scope	9
3	Unpacking	9
4	External Indication	9
4.1	DR60 Nameplate	9
5	Key Features	10
6	Compliance	11
6.1	Standard Compliance	11
6.2	EMC Compliance	11
6.3	Product Safety	11
6.4	R&TTE Compliance	12
7	Functional Overview	12
8	Programs Under the GPL License	12
9	Ordering Options	15
Chapter 2: Safety Information		17
1	Health and Safety	17
2	Symbols	17
3	Installation, Commissioning and Servicing	18
3.1	Lifting Hazards	18
3.2	Electrical Hazards	18
3.3	Fusing Requirements	20
3.4	Equipment Connections	21
3.5	Pre-energization Checklist	22
3.6	Peripheral Circuitry	22
3.7	Upgrading/Servicing	23
4	Decommissioning and Disposal	23
Chapter 3: Design		25
1	Hardware Architecture	25
2	Mechanical Implementation	26
2.1	DR60 Connections Overview and Indicators	26
Chapter 4: Configuration		30
1	DR60 Configurator Tool	30
1.1	Main Screen	30
1.2	Configuration Tabs	32
1.3	Status Bar	34

2	Access Levels	34
3	Communication Setup and Configuration Files Use	35
3.1	Configuring Communication Parameters	36
3.1.1	IP Address Scanning	37
3.2	Creating a New Configuration File	37
3.3	Receiving an Equipment Configuration File	37
3.4	Opening a Pre-existing Configuration File	38
3.5	Saving a Configuration File	38
3.6	Sending a Configuration File for the Equipment	38
4	Administrative Tools	38
5	Configuration Tabs	39
5.1	General	39
5.2	Analog	40
5.2.1	Bay Arrangement (MMXU/MMXN)	40
5.2.2	Generic Sensor (TGSN) – Transducer inputs	42
5.3	Binary	42
5.3.1	Binary Inputs Subtab	42
5.3.2	GOOSE Inputs	43
5.4	Communication	43
5.4.1	Physical	43
5.4.2	Datasets	45
5.4.3	GOOSE Publisher	46
5.4.4	GOOSE Subscriber	46
5.4.5	Reports	47
5.4.6	C37.118.2-2011 (PMU)	49
5.4.7	DNP3	50
5.5	Synchronization	51
5.5.1	Synchronization	51
5.5.2	PTP Configuration	52
5.5.3	Ethernet Network Synchronism Recommendations	53
5.6	Recording	54
5.7	Triggering	55
5.7.1	Thresholds	55
5.7.2	Equations	58
5.7.3	Matrix	59
6	Monitoring and Web Interface	60
7	Alarm and Warning Reporting	61
Chapter 5: Records		63
1	Waveform Records	63
1.1	Recorded Values	63
1.2	Recording Times by Trigger	63
1.3	Sampling Rate	64

1.4	Trigger Burst Limiter	64
2	Re-trigger and Record Concatenation	64
3	Disturbance and Continuous Disturbance Records	65
3.1	Recorded Values	65
3.2	Recording Times by Trigger	68
3.3	Frequency Calculation	69
3.4	Sampling Rate	69
3.5	Trigger Burst Limiter	69
4	Trend Recorder	69
5	SOE - Sequence of Events Records	69
5.1	Sampling Rate	69
6	Record Format and Naming, and Mass Storage Capacity	70
6.1	Record Format	70
6.2	Record Naming	70
6.3	Mass Storage Capacity	71
7	Record Management and Access	71
7.1	Creating Installations	72
7.2	Creating Devices	72
Chapter 6: Impedance Fault Location		75
1	Impedance Fault Location Introduction	75
2	Advanced Configuration	75
2.1	Communication – DNP3	76
Chapter 7: PMU		78
1	Synchrophasor Measurement and Broadcast	78
1.1	Reported Values	78
1.2	Accuracy Limits	79
1.3	Communication Ports, Transmission Rates	79
1.4	Configuration	80
1.5	Transmission Protocol	82
1.6	Communication Mode	82
1.6.1	Spontaneous	83
1.6.2	Commanded	83
1.7	Ethernet interfaces and PMU Routes	83
1.8	PMU Standards Compliance	84
1.9	PMU Specification	85
Chapter 8: Communications		86
1	Communication Interfaces – Slot B	86
1.1	Electrical and Optical Ethernet	86
1.1.1	Ethernet Port Default Settings	87
1.2	Serial Port	87
2	Communication Ports and Protocols	88

3	Recovering the DR60 IP Address	89
4	Accessing the Equipment	89
4.1	Web Interface Minimum Requirements	89
Chapter 9: Installation		91
1	Handling the Goods	91
1.1	Receipt of the Goods	91
1.2	Unpacking the Goods	91
1.3	Storing the Goods	91
1.4	Dismantling the Goods	92
2	Normal Use of the Equipment	92
3	Mounting the Device	92
3.1	DR60 Mechanical Installation	92
4	Cables and Connectors	93
4.1	Power Supply Connections	94
4.1.1	AC and DC Power Connection	95
4.2	Powering Up	95
4.3	Earth Connection	96
4.4	IN SERVICE Contact	97
4.5	Optical IRIG-B Input	98
4.6	Serial ports	98
4.7	I/O Nomenclature	99
4.8	Binary Inputs and Outputs/	100
4.8.1	Binary Inputs	102
4.8.2	Binary Outputs	103
4.9	Voltage and Current Analog Inputs	104
4.9.1	Current Analog Inputs	105
4.9.2	Voltage Analog Inputs	105
5	Case Dimensions	106
5.1	DR60 Dimensions and Weight	106
5.2	Panel Cutout	107
5.3	Accessories	107
5.3.2	Mounting Panel for Two DR60 (Q061)	108
6	DR60 Configurator Tools Installation	108
6.1	Minimal requirements	108
Chapter 10: Maintenance		110
1	Maintenance	110
1.1	Maintenance Checks	110
1.1.1	In-service maintenance	111
1.1.2	Out-of-service maintenance	111
1.1.3	Unscheduled maintenance (system interruption)	111
1.2	Backup and restore settings	111

1.3	Measurement Accuracy	111
1.4	Replacing the Unit	111
1.5	Cleaning	112
1.6	Watchdog	112
2	DR60 Firmware Update	112
3	Procedure to reset password	112
4	Equipment Return	113
5	Instructions for Equipment Repair/Service for Service Personnel	113
Chapter 11: Technical Specifications		115
<hr/>		
1	DR60 Specifications	115
1.1	Power Supply	115
1.2	Ethernet Ports	115
1.3	Optical IRIG-Input	116
1.4	Serial Ports	116
1.5	Dry-contact Relay Outputs	117
1.6	Analog Acquisition	118
1.7	Voltage Inputs	118
1.8	Current Inputs	119
1.9	DC Transducer Inputs	120
1.10	Binary Inputs	120
1.11	Binary Outputs	120
1.12	Environmental Conditions	121
1.13	Type Tests DR60	121
1.14	Safety Tests	124
1.15	Environmental tests	124
1.16	Dimensions	125
Chapter 12: Wiring Diagrams		126
<hr/>		
1	Connection Diagrams of the Voltage Inputs	126
2	Connection Diagrams of the Current Inputs	128
Appendix A – Equipment Log		131
<hr/>		
1	Equipment Log	131

DR60

Digital Recorder

Chapter 1: Introduction

This chapter provides some general information about the technical manual and an introduction to the device(s) described in this technical manual.

1 Foreword

This technical manual provides a functional and technical description of GE Reason DR60, as well as a comprehensive set of instructions for using the device. The level at which this manual is written assumes that you are already familiar with protection engineering and have experience in this discipline. The description of principles and theory is limited to that which is necessary to understand the product.

We have attempted to make this manual as accurate, comprehensive and user-friendly as possible. However, we cannot guarantee that it is free from errors. Nor can we state that it cannot be improved. We would therefore be very pleased to hear from you if you discover any errors or have any suggestions for improvement. Our policy is to provide the information necessary to help you safely specify, engineer, install, commission, maintain, and eventually dispose of this product. We consider that this manual provides the necessary information, but if you consider that more details are needed, please contact us.

All feedback should be sent to our contact center via the following URL:

<http://www.gegridsolutions.com/alstomenergy/grid/grid/contactcentre>

1.1 Target Audience

This manual is aimed towards all professionals charged with installing, commissioning, maintaining, troubleshooting, or operating any of the products within the specified product range. This includes installation and commissioning personnel as well as engineers who will be responsible for operating the product.

The level at which this manual is written assumes that installation and commissioning engineers have knowledge of handling electronic equipment. Also, system and protection engineers have a thorough knowledge of protection systems and associated equipment.

1.2 Nomenclature

Due to the technical nature of this manual, many special terms, abbreviations and acronyms are used throughout the manual. Some of these terms are well-known industry-specific terms while others may be special product-specific terms used by GE.

1.3 Abbreviations

AC - Alternating Current;
COMNAME - IEEE C37.232 Recommended Practice for Naming Time Sequence Data Files;
COMTRADE - IEEE C37.111 Common Format for Transient Data Exchange;
CID – Configured IED Description
DC - Direct Current;
DFR – Digital Fault Recorder;
EMC - Electromagnetic Compatibility;
FRQ - Frequency;
GOOSE - Generic Object Oriented Substation Events;
GMC – Grandmaster Clock
GPS - Global Positioning System;
HTML - HyperText Markup Language;
IMB - Imbalance;
IEEE - Institute of Electric and Electronic Engineers;
IEC - International Electrotechnical Commission;
IED - Intelligent Electronic Devices;
IP - Internet Protocol;
IRIG-B -Inter Range Instrumentation Group (Rate Designation B);
KML - Keyhole Markup Language;
MAC - Media Access Control;
MODBUS - Modicon Bus;
PC - Computer;
PMU - Phasor Measurement Unit;
PPC – Points per cycle;
Pst - Short-term flicker severity;
Plt - Long-term flicker severity;
RAM - Random-access Memory;
RFC, DEFLATE - RFC 1951, DEFLATE Compressed Data Format Specification;
RMS - Root Mean Square;
SCADA - Supervisory Control and Data Acquisition;
SCD – Substation Configuration Description
SCL - Edit Configuration File for the GOOSE Configurator;
SNTP - Simple Network Time Protocol;
SOE - Sequence of Events;
SQL - Structured Query Language;
SSD - Solid-State Drive;
TCP - Transmission Control Protocol;
THD - Total harmonic distortion;
TTL – Transistor-transistor-logic;
TW - Travelling Wave;
UDP - User Datagram Protocol;
UTC - Coordinated Universal Time;
VLAN - Virtual Local Area Network;
XML - Extensible Markup Language.

2 Product Scope

The DR60 a single-box solution for Digital Recording. The solution is designed for the acquisition, monitoring and recording of electrical quantities normally associated with electrical power generation, transmission or distribution equipment. The DR60 is designed fan-less and no rotating part components. It has a 16-bit acquisition system that provide an acquisition rate of 256 or 512 samples/cycle synchronized by the IRIG-B or IEEE 1588 PTPv2.

The DR60 has a very flexible architecture with several different boards with allows the customer to choose the most cost-effective solution for each application. Depending on the boards combination, the DR60 can offer: up to 32 analog channels, 96 digital channels and 48 digital outputs

The DR60 is a native IEC 61850 device, which means that all its internal variables follow the data models and logical nodes described in the IEC 61850 edition 2. The DR60 can publish and subscribe to GOOSE messages, as well as publish Report control blocks for supervisory system integration.

It allows communication through the electrical Ethernet ports or optical interfaces.

3 Unpacking

Unpack the equipment carefully and make sure that all accessories and cables are put away so they will not be lost.

Check the contents against the packing list. If any of the contents listed is missing, please contact GE immediately (see contact information at the beginning of this manual).

Examine the equipment for any shipping damage. If the unit is damaged or fails to operate, notify the shipping company immediately. Only the consignee (the person or company receiving the unit) can file a claim against the carrier for occasional shipping damages.

We recommend that the user retain the original packing materials for use in case of need to transport or ship the equipment at some future time.

4 External Indication

4.1 DR60 Nameplate

Information about the company, power supply, the serial number and part number is shown on a small nameplate affixed to the rear of the equipment, as shown in figure below.



Location of Serial Number, Part Number and specifications

5 Key Features

The DR60 presents the following key features:

- Acquisition system:
 - 16-bit opto-isolated analog-to-digital converters, independent for each channel (50/60 Hz channels);
 - 256 and 512 samples/cycle (50/60 Hz channels);
 - Frequency response of DC to approximately 3.0 kHz;
 - Opto-isolated digital inputs
 - Internal time skew compensation;
 - Sampling rate synchronized to external time reference;
- Channel capacity:
 - Up to 16 voltage inputs;

- Up to 16 current inputs;
 - Up to 16 transducer voltage inputs;
 - Up to 16 transducer current inputs;
 - Up to 96 digital inputs;
- Note: Maximum capacity of channels depends on boards combination
- Fan-less and no rotating part design
 - Waveform recorder at 256 and 512 samples/cycle;
 - Disturbance and continuous disturbance at 1, 2 or 4 samples/cycle;
 - IRIG-B004 and IEEE 1588 PTPv2
 - Trigger using Boolean logic equations;
 - GOOSE publisher and subscriber (up to 256 GOOSE inputs)
 - MMS report control block publisher
 - Cross-trigger using GOOSE messages;
 - RS232 serial ports for configuration;
 - 1 failsafe contact (normally closed dry contact relay);

6 Compliance

The DR60 product has undergone a range of extensive testing and certification processes to ensure and prove compatibility with all target markets. A detailed description of these criteria can be found in the Technical Specifications Chapter.

6.1 Standard Compliance

Compliance with the European Commission Directive, UK Conformity Assessed on EMC and LVD is demonstrated by self-certification against international standards.



6.2 EMC Compliance

Compliance with IEC 60255-26:2013 was used to establish conformity.

6.3 Product Safety

Compliance with IEC 60255-27:2014 was used to establish conformity.

Protective Class

IEC 60255-27:2014 Protective Class 1. This equipment requires a protective conductor (earth) to ensure user safety.

Installation category

- When using the 100-250 Vdc / 110-240 Vac power supply: IEC 60255-27:2013 Installation category III (Overvoltage Category III). Equipment in this category is

qualification tested at 5kV peak, 1.2/50 μ S, 500 Ohms, 0.5 J, between all supply circuits and earth and between independent circuits.

- When using the 24-48 Vdc power supply: IEC 60255-27:2013 Installation category II (Overvoltage Category II)

Environment

IEC 60068-2-1, IEC 60068-2-2, IEC 60068-2-30, IEC 60068-2-14, IEC 60255-21-1, IEC 60255-21-2. The equipment shall always be installed in a specific cabinet or housing which will enable it to meet the requirements of IEC 60529 with the classification of degree of protection IP54 or above.

6.4 R&TTE Compliance

Radio and Telecommunications Terminal Equipment (R&TTE) directive 99/5/EC.

7 Functional Overview

It is a single-box solution design for substation environment and offers a very flexible combination of boards, which allows the customers to have up to 32 analog inputs and up to 96 binary inputs. These characteristics along with binary outputs options and two Ethernet ports, make the DR60 ideal to monitor up to 3 bays (considering 8 analog and 16 binary inputs per bay).

The DR60 provides a cost-effective solution for disturbance recording through a distributed approach. It can be installed locally on a per-feeder basis or interconnected via peer-to-peer GOOSE messaging that allows cross-triggering to occur without the need to hard-wire the contacts, providing a scalable solution to station-level recording.

The DR60 complements relays by providing independent, high fidelity waveform capture. It provides Waveform recorders, SOE and triggered and continuous disturbance recorders - not typically found even in the most advanced digital relays. It also provides features such GOOSE publisher and subscriber and MMS report control blocks for integration with supervisory systems.

8 Programs Under the GPL License

The DR60 uses GPL licenses in its implementation according to the following table:

PACKAGE	LICENSE
glibc	GPLv2+ (programs), LGPLv2.1+, BSD-3c, MIT (library)
linux-headers	GPLv2
bash	GPLv3+
busybox	GPLv2
ncurses	MIT with advertising clause
readline	GPLv3+
e2fsprogs	GPLv2, libuuid BSD-3c, libss and libet MIT-like with advertising clause
util-linux	GPLv2+, BSD-4c, libblkid and libmount LGPLv2.1+, libuuid BSD-3c
zlib	zlib license
ethtool	GPLv2
gptfdisk	GPLv2+
htop	GPLv2
irqbalance	GPLv2
lighttpd	BSD-3c
pcre	BSD-3c
mtid	GPLv2
mxml	LGPLv2+ with exceptions
netnmp	Various BSD-like
openssl	OpenSSL or SSLeay
openssh	BSD-3c BSD-2c Public Domain
parted	GPLv3+
pps-tools	GPLv2+
sudo	ISC BSD-3c
uboot-tools	GPLv2+
vsftpd	GPLv2
linux	GPLv2
kermit	BSD
libiec61850	GPLv3
mms-client	GPLv3
ntp-internal	ntp license
ptpd-internal	BSD

9 Ordering Options

Variants	Order Number													
	1-4	5	6	7-8	9-10	11-12	13-14	15-16	17-18	19-20	21	22-23	24	25
Model type: DR60 Digital Recorder	DR 60													
Slot A - Power Supply 24-48 Vdc 100-250 Vdc / 110-240 Vac		1 3												
Slot B - Hardware Options Processing unit + two RJ45 copper 10/100BASE-TX Ethernet interfaces Processing unit + two multimode LC-type connector 100BASE-FX Ethernet interfaces			E O											
Slot C - Binary I/O 16 x 24/48/125/250 V binary inputs 6 x 24/48/125/250 V binary inputs and 8 x binary outputs Not installed				B1 B2 XX										
Slot D - Binary I/O 16 x 24/48/125/250 V binary inputs 6 x 24/48/125/250 V binary inputs and 8 x binary outputs Not installed					B1 B2 XX									
Slot E - Flexible I/O Options 16 x 24/48/125/250 V binary inputs 6 x 24/48/125/250 V binary inputs and 8 x binary outputs 4 x VT 115 V and 4 CT 1/5 A RMS measurement analog inputs 4 x VT 115 V and 4 x CT 1 A RMS protection analog inputs 4 x VT 115V and 4 x CT 5 A RMS protection analog inputs 4 x ±10 Vdc and 4 x 0-20 mAdc transducer inputs Not installed						B1 B2 ME P1 P5 DC XX								
Slot F - Flexible I/O Options 16 x 24/48/125/250 V binary inputs 6 x 24/48/125/250 V binary inputs and 8 x binary outputs 4 x VT 115 V and 4 CT 1/5 A RMS measurement analog inputs 4 x VT 115 V and 4 x CT 1 A RMS protection analog inputs 4 x VT 115V and 4 x CT 5 A RMS protection analog inputs 4 x ±10 Vdc and 4 x 0-20 mAdc transducer inputs Not installed							B1 B2 ME P1 P5 DC XX							
Slot G - Flexible I/O Options 16 x 24/48/125/250 V binary inputs 6 x 24/48/125/250 V binary inputs and 8 x binary outputs 4 x VT 115 V and 4 CT 1/5 A RMS measurement analog inputs 4 x VT 115 V and 4 x CT 1 A RMS protection analog inputs 4 x VT 115V and 4 x CT 5 A RMS protection analog inputs 4 x ±10 Vdc and 4 x 0-20 mAdc transducer inputs								B1 B2 ME P1 P5 DC						

Not installed	XX	
Slot H - Flexible I/O Options 16 x 24/48/125/250 V binary inputs 6 x 24/48/125/250 V binary inputs and 8 x binary outputs 4 x VT 115 V and 4 CT 1/5 A RMS measurement analog inputs 4 x VT 115 V and 4 x CT 1 A RMS protection analog inputs 4 x VT 115V and 4 x CT 5 A RMS protection analog inputs 4 x ±10 Vdc and 4 x 0-20 mAdc transducer inputs Not installed	B1 B2 ME P1 P5 DC XX	
Primary Functions Phasor Measurement Unit (PMU) Waveform recorder Disturbance Recorder Continuous Disturbance Recorder Trend Recorder	** ** ** ** **	
Secondary Functions Standard Issue		1
Firmware Version Latest available firmware - 02		02
Warranty Standard warranty		0
Hardware Design Suffix Initial version		A

Issue B

DR60

Digital Recorder

Chapter 2: Safety Information

This chapter provides information about the safe handling of the equipment. The equipment must be properly installed and handled in order to maintain it in a safe condition and to keep personnel safe at all times. You must be familiar with information contained in this chapter before unpacking, installing, commissioning, or servicing the equipment.

1 Health and Safety

Personnel associated with the equipment must be familiar with the contents of this Safety Information.

When electrical equipment is in operation, dangerous voltages are present in certain parts of the equipment. Improper use of the equipment and failure to observe warning notices will endanger personnel.

Only qualified personnel may work on or operate the equipment. Qualified personnel are individuals who are:

- familiar with the installation, commissioning, and operation of the equipment and the system to which it is being connected.
- familiar with accepted safety engineering practices and are authorized to energize and de-energize equipment in the correct manner.
- trained in the care and use of safety apparatus in accordance with safety engineering practices
- trained in emergency procedures (first aid).

The documentation provides instructions for installing, commissioning and operating the equipment. It cannot, however, cover all conceivable circumstances. In the event of questions or problems, do not take any action without proper authorization. Please contact your local sales office and request the necessary information.

Each product is subjected to routine production testing for Dielectric Strength and Protective Bonding Continuity

2 Symbols

Throughout this manual you will come across the following symbols. You will also see these symbols on parts of the equipment.



Caution: Refer to equipment documentation. Failure to do so could result in damage to the equipment



Risk of electric shock



Ground terminal. Note: This symbol may also be used for a protective conductor (ground) terminal if that terminal is part of a terminal block or sub-assembly.



Protective conductor (ground) terminal

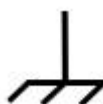

Chassis functional earth terminal



Both direct and alternating current



Instructions on disposal requirements

The term 'Ground' used in this manual is the direct equivalent of the European term 'Earth'.

3 Installation, Commissioning and Servicing

3.1 Lifting Hazards

Many injuries are caused by:

- Lifting heavy objects
- Lifting things incorrectly
- Pushing or pulling heavy objects
- Using the same muscles repetitively

Plan carefully, identify any possible hazards and determine how best to move the product. Look at other ways of moving the load to avoid manual handling. Use the correct lifting techniques and Personal Protective Equipment (PPE) to reduce the risk of injury.

3.2 Electrical Hazards



All personnel involved in installing, commissioning, or servicing this equipment must be familiar with the correct working procedures.



Consult the equipment documentation before installing, commissioning, or servicing the equipment.



Always use the equipment as specified. Failure to do so will jeopardize the protection provided by the equipment.



Removal of equipment panels or covers may expose hazardous live parts. Do not touch until the electrical power is removed. Take care when there is unlocked access to the rear of the equipment.



Isolate the equipment before working on the terminal strips.



Use a suitable protective barrier for areas with restricted space, where there is a risk of electric shock due to exposed terminals.



Disconnect power before disassembling. Disassembly of the equipment may expose sensitive electronic circuitry. Take suitable precautions against electrostatic voltage discharge (ESD) to avoid damage to the equipment.



NEVER look into optical fibers or optical output connections. Always use optical power meters to determine operation or signal level.



Testing may leave capacitors charged to dangerous voltage levels. Discharge capacitors by reducing test voltages to zero before disconnecting test leads.



If the equipment is used in a manner not specified by the manufacturer, the protection provided by the equipment may be impaired.



Operate the equipment within the specified electrical and environmental limits.



Before cleaning the equipment, ensure that no connections are energized. Use a lint free cloth dampened with clean water.



Integration of the equipment into systems shall not interfere with its normal functioning.



The functioning of the device has been certified under the circumstances described by the standards mentioned in Technical Specifications chapter (item Type Tests). Usage of the equipment in different conditions from the specified in this manual might affect negatively its normal integrity.



The equipment shall have all their rear connectors attached even if they are not being used, in order to keep their levels of ingress protection as high as possible



Never manipulate liquid containers near the equipment even when it is powered off.



Avoid modification to the wiring of panel when the system is running.



VT circuits must never be left short circuited.

3.3 Fusing Requirements



A high rupture capacity (HRC) fuse type with a maximum current rating of 10 Amps and a minimum dc rating of 250 V dc may be used for the auxiliary supply (for example Red Spot type NIT or TIA). Alternatively, a miniature circuit breaker (MCB) of type C, 10A rating, compliant with IEC 60947-1 and IEC 60947-3 may be used.



Digital input circuits should be protected by a high rupture capacity NIT or TIA fuse with maximum rating of 10 A, or equivalent MCB as above. For safety reasons, current transformer circuits must never be fused. Other circuits should be appropriately fused to protect the wire used.



Reason devices contain an internal fuse for the power supply which is only accessed by opening the product. This does not remove the requirement for external fusing or use of an MCB as previously mentioned. The ratings of the internal fuses are:
DR60 unit: 2 Amp, type T, 250V rating



CTs must NOT be fused since open circuiting them may produce lethal hazardous voltages.

3.4 Equipment Connections



Terminals exposed during installation, commissioning and maintenance may present a hazardous voltage unless the equipment is electrically isolated.



Tighten M3 clamping screws of heavy duty terminal block connectors to a nominal torque of 1.0 Nm.
Tighten captive screws of header-type (Euro) terminal blocks to 0.5 Nm minimum and 0.6 Nm maximum.



Always use insulated crimp terminations for voltage and current connections.



Always use the correct crimp terminal and tool according to the wire size.



In order to maintain the equipment's requirements for protection against electric shock, other devices connected to the DR60 shall have protective class equal or superior to Class I.



Watchdog (self-monitoring) contacts are provided to indicate the health of the device on some products. We strongly recommend that you hard wire these contacts into the substation's automation system, for alarm purposes.



Earth the equipment with the supplied PCT (Protective Conductor Terminal).



Do not remove the PCT.



The PCT is sometimes used to terminate cable screens. Always check the PCT's integrity after adding or removing such earth connections.



The user is responsible for ensuring the integrity of any protective conductor connections before carrying out any other actions.



The PCT connection must have low-inductance and be as short as possible. For best EMC performance, ground the unit using a 10 mm (0.4 inch) wide braided grounding strap.



All connections to the equipment must have a defined potential. Connections that are pre-wired, but not used, should be earthed, or connected to a common grouped potential.



Pay extra attention to diagrams before wiring the equipment. Always be sure that the connections are correct before energizing the circuits.



3.5 Pre-energization Checklist



Check voltage rating/polarity (rating label/equipment documentation).



Check CT circuit rating (rating label) and integrity of connections.



Check protective fuse or miniature circuit breaker (MCB) rating.



Check integrity of the PCT connection.



Check voltage and current rating of external wiring, ensuring it is appropriate for the application.

3.6 Peripheral Circuitry



Do not open the secondary circuit of a live CT since the high voltage produced may be lethal to personnel and could damage insulation. Short the secondary of the line CT before opening any connections to it.

Reason devices DO NOT feature any automatic CT shorting feature. Therefore, external shorting of the CTs is mandatory. Check the equipment documentation and wiring diagrams carefully.



Where external components such as resistors or voltage dependent resistors (VDRs) are used, these may present a risk of electric shock or burns if touched.



Operation of computers and equipment connected to the DR60 under environmental conditions such as temperature and humidity that exceed the conditions specified in their respective manuals can cause malfunctioning or even irreversible damage to them or the nearby installation.



There might be situations in which the DR60 is operating within its environmental operational range, but the computers, equipment connected to them or nearby equipment are operating outside their operational range. That situation can cause malfunctioning and/or irreversible damage to those devices. In that occasion the communication to the Reason equipment might be compromised but its recording, operational and safety capacities will not be affected.



Take extreme care when using external test blocks and test plugs such as the MMLG, MMLB and P990, as hazardous voltages may be exposed. Ensure that CT shorting links are in place before removing test plugs, to avoid potentially lethal voltages.

3.7 Upgrading/Serviceing



Do not insert or withdraw modules, PCBs or expansion boards from the equipment while energized, as this may result in damage to the equipment. Hazardous live voltages would also be exposed, endangering personnel.



Internal modules and assemblies can be heavy and may have sharp edges. Take care when inserting or removing modules into or out of the IED.

4 Decommissioning and Disposal



Before decommissioning, completely isolate the equipment power supplies (both poles of any dc supply). The auxiliary supply input may have capacitors in parallel, which may still be charged. To avoid electric shock, discharge the capacitors using the external terminals before decommissioning.



Avoid incineration or disposal to water courses. Dispose of the equipment in a safe, responsible and environmentally friendly manner, and if applicable, in accordance with country-specific regulations.

DR60

Digital Recorder

Chapter 3: Design

This chapter provides information about the hardware design of the products.

1 Hardware Architecture

The DR60 is composed of up to 8 boards, from slot A to H. A very flexible number of inputs and outputs can be achieved by the combination of the boards. The slot A is reserved for power supply; Slot B for CPU, Ethernet and serial connection and IRIG-B synchronization input; Slots C and D are used for binary input/outputs and slots E to H can be used either for binary I/O or analog inputs. The figure below illustrates the DR60 slots composition. For the complete list of board option, refer to the ordering option in Chapter 1.

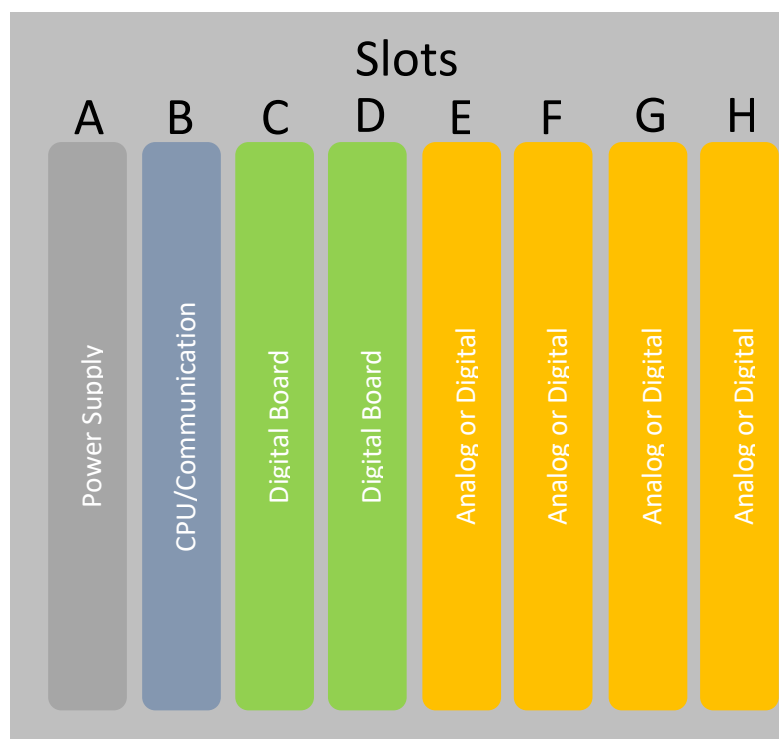

DR60 slots composition

2 Mechanical Implementation

2.1 DR60 Connections Overview and Indicators

The figure below shows the DR60 front panel with connectors and indicator LEDs.

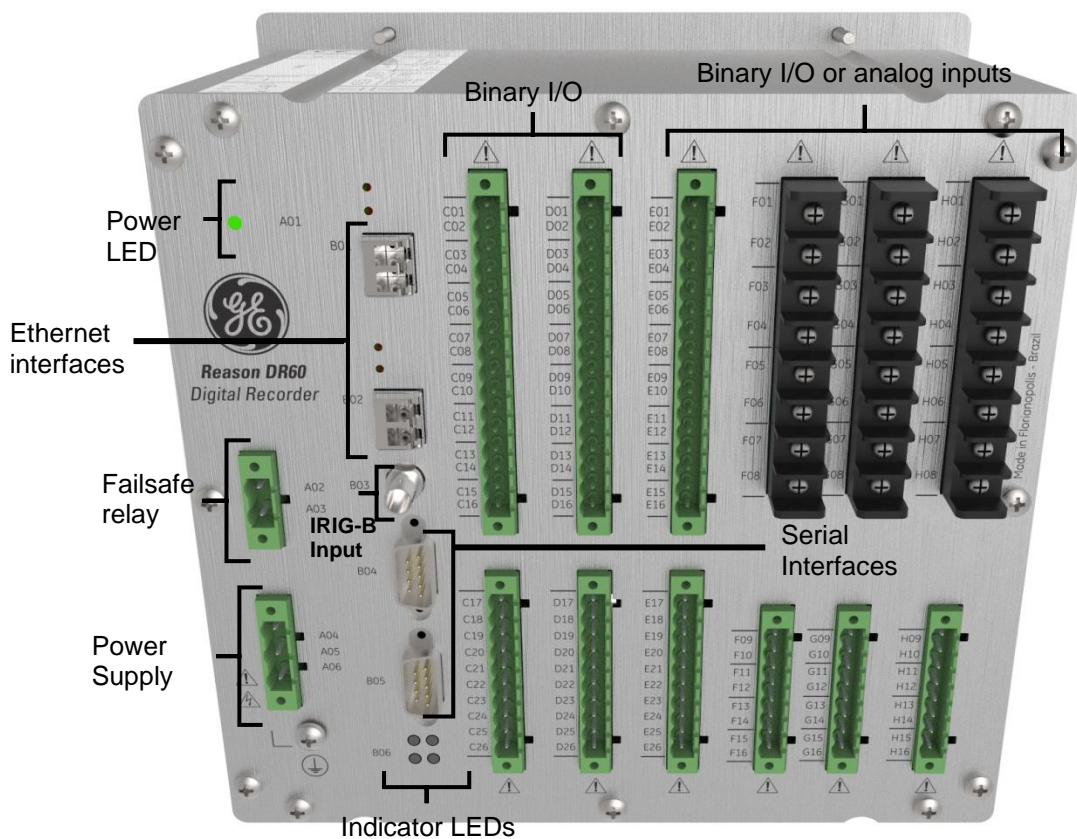

Front View of the DR60

The diagram and table below show the designation and meaning of each LED.

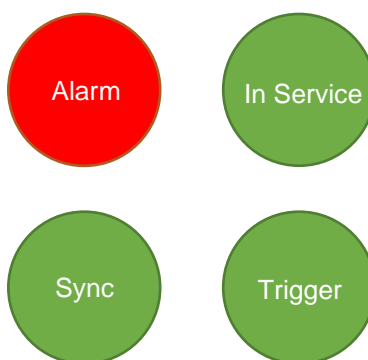

LED	Color	Indicator	Meaning
Alarm	Orange	Warning	An alarm event that <u>does not</u> compromise the DR60 functions was detected
	Red	Alarm	An alarm event that compromised DR60 functions was detected
In Service	Green	In Service	DR60 is working in perfect conditions
Sync	Green	Global	DR60 is synchronized with the time reference clock that is synchronized with satellite reference
	Orange	Local	DR60 is synchronized with the time reference clock that is <u>not</u> synchronized with satellite reference
Trigger	Blink Green	Trigger	Any trigger occurred
	Blink Orange	Re-trigger	Any trigger reoccurred

The table below shows which events are considered alarms and warnings and all these events are accessible through MMS in DR60 datamodel and can be published through GOOSE messages.

Alarms	Data Name	Description
Sync NOT OK	BSE/ALARMSGGIO1.Alm1	Equipment not sync (free-running state)
Card not detected, invalid or incompatible	BSE/ALARMSGGIO1. Alm2	Happens when there are discrepancies between the installed boards and the device CORTEC
Internal voltage	BSE/ALARMSGGIO1. Alm3	Internal voltage automonitoring alarm
Internal temperature	BSE/ALARMSGGIO1. Alm4	Internal temperature is abnormal (Out of -10°C to 60°C)
No communication Ethernet interface 1	BSE/ALARMSGGIO1. Alm5	Loss of communication of the main interface. If no network redundancy losing communication with ethernet interface

		1. With redundancy if lose communication with both ethernet interfaces.
Waveform/Fault recorder memory usage above 98%	BSE/ALARMSGGIO1. Alm6	Happens when the memory becomes 98% full for Waveform recorder
Disturbance recorder memory usage above 98%	BSE/ALARMSGGIO1. Alm7	Happens when the memory becomes 98% full for Disturbance recorder
Trend recorder memory usage above 98%	BSE/ALARMSGGIO1. Alm8	Records memory exceeds 98% for Trend recorder
SOE recorder memory usage above 98%	BSE/ALARMSGGIO1. Alm9	Records memory exceeds 98% for SOE recorder

Warnings	Data Name	Description
Sync in Local or Holdover state	BSE/ALARMSGGIO1.Wrn1	GMC lost antenna signal or DR60 has lost the signal from GMC and is within its accuracy requirements
No communication Ethernet interface 2	BSE/ALARMSGGIO1. Wrn5	Partial loss of communication. If no redundancy if lose communication with ethernet interface 2. With redundancy if lose communication with one of the interfaces.
Waveform/Fault recorder memory usage above 90%	BSE/ALARMSGGIO1. Wrn6	Happens when the memory becomes 90% full for waveform recorder
Disturbance recorder memory usage above 90%	BSE/ALARMSGGIO1. Wrn7	Happens when the memory becomes 90% full for disturbance recorder
Trend recorder memory usage above 90%	BSE/ALARMSGGIO1. Wrn8	Records memory exceeds 90% for Trend recorder

SOE recorder memory usage above 90%	BSE/ALARMSGGIO1. Wrn9	Records memory exceeds 90% for SOE recorder
GOOSE Subscriber failure or timeout	BSE/ALARMSGGIO1. Wrn10	Time for the next expected GOOSE message to come exceeded

DR60

Digital Recorder

Chapter 4: Configuration

This chapter includes detailed instructions of how to configure all available features in the device.

1 DR60 Configurator Tool

The DR60 Configurator is the DR60's ICT (IED configuration tool). It allows the modification of all configurable functionalities of the device, including communication aspects, recorders, binary I/O etc.

1.1 Main Screen

The figure below shows the main screen of the DR60 Configurator. This screen is accessed by opening an existing configuration, reading the device configuration or creating a new configuration.

The DR60 Configurator is available in the following languages:

- English;
- French;
- Spanish and;
- Portuguese.

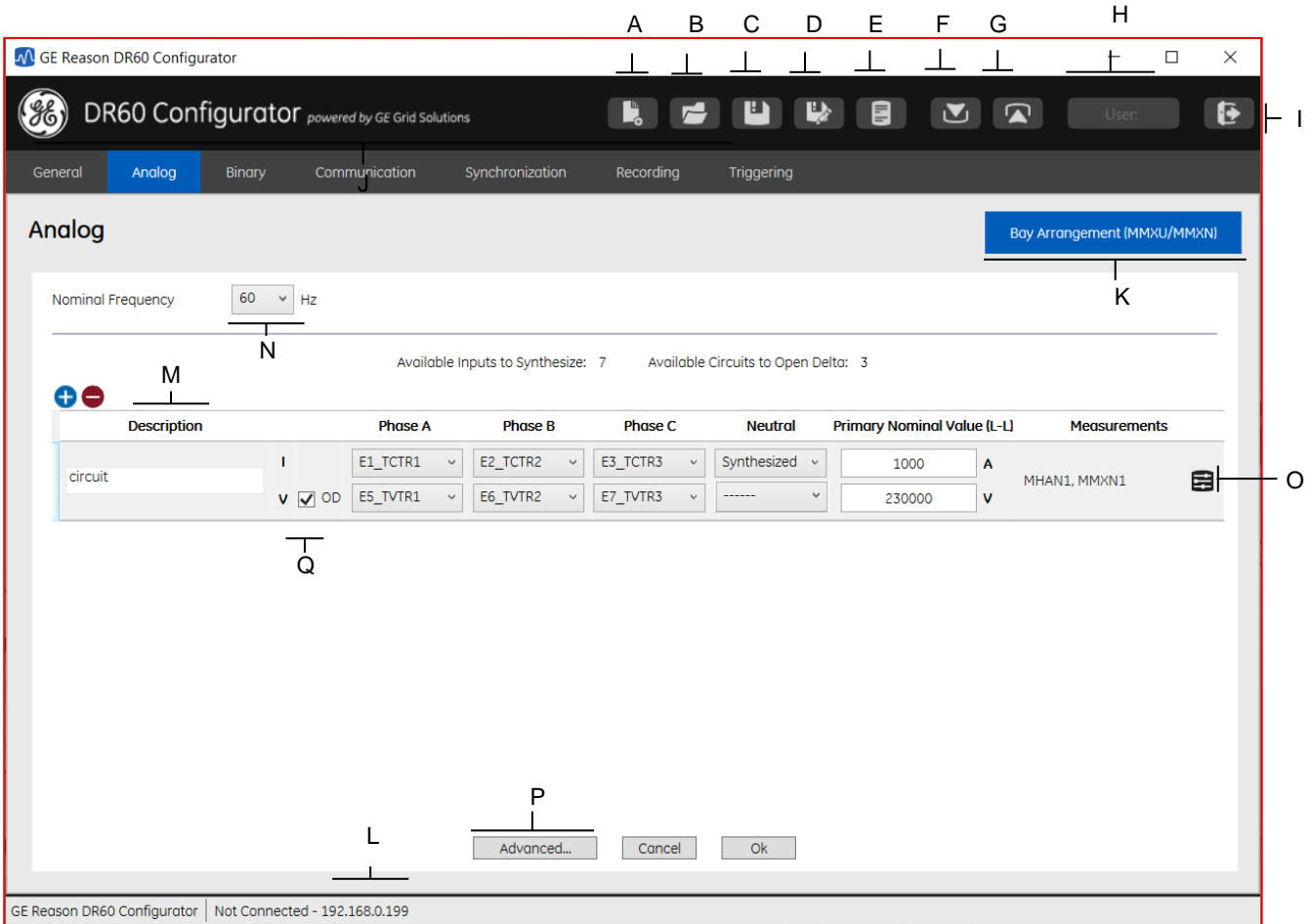

DR60 Configurator main screen

Below is described the main common menu options on the screen according to the highlights on the figure above:

- A** Menu bar: New Configuration.
- B** Menu bar: Open Configuration.
- C** Menu bar: Save Configuration.
- D** Menu bar: Save Configuration As.
- E** Export Configuration Report: Exports PDF report with the configured parameters.
- F** Menu bar: Receive Configuration: download configuration from the DR60.
- G** Menu bar: Send Configuration: send configuration to the DR60.
- H** Menu bar: User: Shows which level of user is currently connected (Configuration or Administration).
- I** Menu bar: Exit
- J** Configuration tabs: contain all the device configuration divide by categories.
- K** Configuration sub-tabs: divide a tab the configuration into groups for ease of configuration
- L** IP address of the DR60 currently connected to the DR Configurator.
- M** Add a new circuit or remove the selected circuit. Selecting a circuit and pressing delete will also remove the circuit.
- N** Selects the nominal frequency of the system (50 Hz or 60 Hz)
- O** Access advanced circuit configurations allowing to enable different measurements and functions and configure extra parameters for the circuit
- P** Access advanced configuration for the channels allowing change channel name and secondary value
- Q** Indicates that the voltage wiring is 2-element type and will have open delta (OD) connection

Note:

For Open delta connection each circuit must be measured by the same analog module, phase AB and phase CB must be the wired respectively to the first and the third voltage channel of this module (e.g. TVTR1 and TVTR3). The second channel of this analog module must configured on the position equivalent to phase B (e.g TVTR2).

1.2 Configuration Tabs

The settings tabs contain all configurable parameters of the equipment divided by categories. There are seven settings tabs, as shown in the figure below.

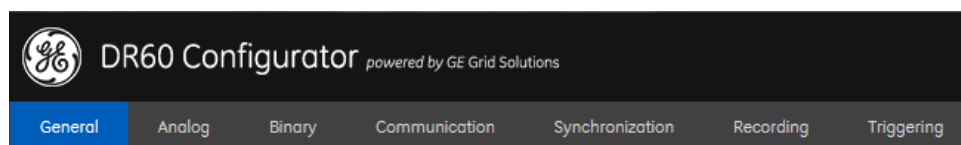

DR60 Configurator Settings Tabs

Through the setting tabs it is possible to configure all the equipment parameters, as detailed on the table below. The possible configurations and the procedure to configure each parameter will be described in the next sections.

Hover the mouse cursor over the text fields of the configurable parameters to show the range of values or the possible characters.

The table below describes the menu options:

Tab	Sub-tab	Description
General	Physical Device (LPHD)	Contains the values and parameters of the Physical Device logical node (LPHD), such as: Model, Identifier, Location etc.
Analog	Bay Arrangements (MMXU/MMXN)	Configures name tags/descriptions and associates the analog physical terminals to the measurements circuits, sets the CT/VT ratios; nominal frequency. Enables calculations such as: RMS, power, frequency, symmetrical components, THD, average values, PMU and impedance fault location
	Generic Sensors (TGSN)	Configures name parameters for the transducer inputs $\pm 10V$ and 20 mA dc
Binary	Binary Inputs	Configures the voltage level, debouncing time and polarity of the binary inputs.
	GOOSE Inputs	Enables and configures the tags of the GOOSE inputs
Communication	Physical	Configures parameters related to the Ethernet and serial ports, such as: IP Address, network mask and etc.
	Dataset	Adds and edits the datasets to be sent via GOOSE or MMS
	GOOSE Publisher	Associates the datasets to GOOSE Control Blocks to be published.
	GOOSE Subscriber	Configures the GOOSE subscriptions using the SCL files from the IEDs publishing GOOSE.
	Reports	Associates the datasets to Report Control Blocks to be published.

	C37.118.2-2011 (PMU)	Configures the communication parameters regarding the PMU streams according to C37.118.2-2011
	DNP3	Configures the communication parameters of the DNP3 stream
Synchronization	Synchronization	Configure the synchronization source/protocol, timezone and daylight saving time parameters.
Recording	Recording	Configures the parameters of the DR60 recorders (Waveform, disturbance, continuous disturbance and SOE), such as: pre, post time, sampling rate and others.
Triggering	Thresholds (RADR)	Contains the thresholds to trigger the DR60 waveform and disturbance recorder
	Equations	Allows the creation of logical equations using the DR60 variables (inputs, logical nodes parameters).
	Matrix	Configures which thresholds, binary/GOOSE inputs or equations will trigger the DR60 recorders. Also, configures the DR60 binary outputs.

1.3 Status Bar

Status bar presents the software name, the connection status (if it is connected, reading or sending configurations), and the Ethernet IP address, as shown in the figure below.

GE Reason DR60 Configurator	Device Connected - DR60_Panel3 - 100.883.158.288
-----------------------------	--

DR60 Configurator Status Bar

2 Access Levels

The DR60 Configurator has three access levels, each one with a corresponding user name.

The **mon** user is able access the DR60 Logs;

The **cfg** user can access the DR60 logs, to create, receive and send configurations and to change its own password.

The **adm** user can do all that **cfg** user is able to, plus firmware update, device key change and alter all users' passwords.

The user names and default password are presented below:

User	Password
cfg	UV@bM8DtqAN
adm	RX8jg3S&mDx
mon	QcURcm"Gk3P

3 Communication Setup and Configuration Files Use

This section describes how to configure the communications parameters and how to manipulate configuration files (CID), using the DR60 Configurator.

The initial screen of the DR60 Configurator application is shown in the figure below and has the following options:

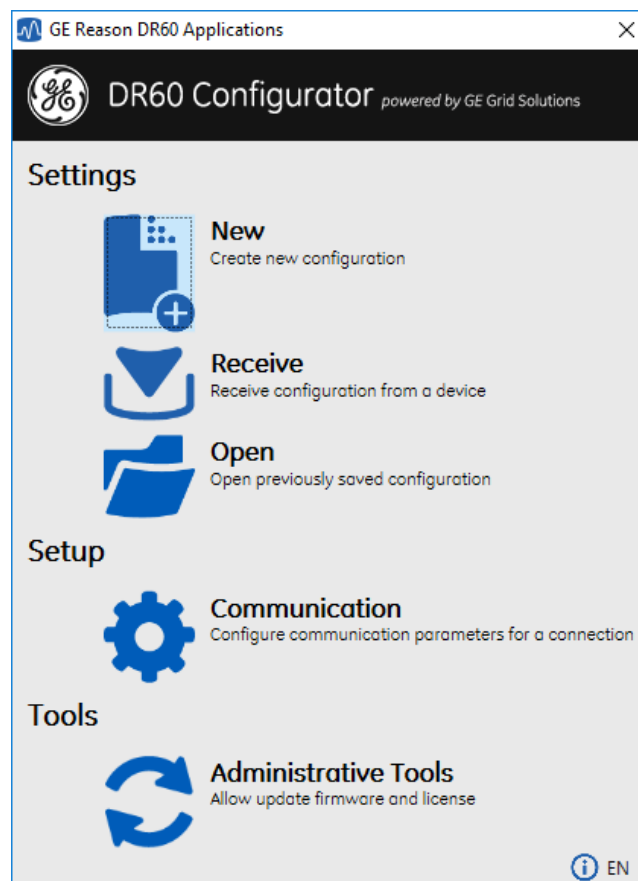

DR60 Configurator initial screen

- A** <New>: creates a new configuration file.
- B** <Receive>: receives a configuration file from the DR60 configured in the Communication menu.
- C** <Open>: this button opens a file containing a pre-existing configuration.
- D** <Communication>: this button opens communications parameters for connecting settings.
- E** <HMI>: this button opens the window containing information about the device.

F <Administrative Tools>: this button opens the window containing the following options:

- Firmware update;
- Key update;
- Access control – allows changing the password for each kind of user (*cfg*, *adm* and *mon*);
- Support file – Downloads a support file containing internal logs used for diagnosis.

On the initial screen, it is also possible to change the software language by clicking the icon on the bottom right corner.

3.1 Configuring Communication Parameters

The <Communication> button on the initial screen opens the Communication Setup screen that allows the configuration of the parameters to connect with the DR60. The DR60 Configurator can communicate with the DR60 using serial RS232 or Ethernet interfaces.

The following options are available on the screen:

- Serial:
 - Ports
 - Speed
 - Data Bits
 - Parity
 - Stop Bits
- Ethernet
 - IP Address
 - Name: inserts the identification name of this connection.
 - Saved Connections: shows the name of the saved connections.
 - <Add>: this button adds a connection name to the Saved Connections area.
 - <Remove>: this button removes a selected connection name from the Saved Connections area.

3.1.1 IP Address Scanning

The DR60 Configurator can scan the Ethernet network and recover the IP Addresses of the connected DR60s. These tools is useful when the IP Address of the DR60 the user wants to communicate is not known.

The IP Address Scanning tool is located on the Communication setup screen.

3.2 Creating a New Configuration File

In order to create a new configuration, click on the <New> button on the initial screen of the DR60 Configurator.

It opens a window to configure the order code of the equipment, according to hardware configuration.

A Order Code: the order code must be created based on the equipment hardware configuration. On each field insert the configuration of the respective slot. The order code of the equipment is displayed on the label affixed on the equipment. For additional information about the formation of the order code, refer to Ordering Options in Introduction Section.

B <Cancel>: this button cancels the order code edition and goes back to the initial screen of the DR60 Configurator.

C <Ok>: this button confirms the order code edition and opens the main screen of the DR60 Configurator.

It is also possible to create a new configuration file through the Main Screen of the DR60 Configurator, by selecting the option New CID on the File menu.

3.3 Receiving an Equipment Configuration File

To receive an online equipment configuration, click on the <Receive> button on the initial screen of the DR60 Configurator. The configurator will communicate with the IP Address or serial configuration configured in the Communication Setup screen and download the DR60 current configuration loading it on the main Screen of the DR60 Configurator.

It is also possible to receive an equipment configuration file from the Main Screen of the DR60 Configurator, by selecting the option Receive Configuration on the Menu Bar. After clicking the Receive button, an authentication window will pop up asking for a user and a password to complete the operation.

The possible user names and passwords are:

User	Password
cfg	UV@bM8DtqAN
adm	RX8jg3S&mDx

3.4 Opening a Pre-existing Configuration File

In order to open a pre-existing configuration, click on the <Open> button on the initial screen of the DR60 Configurator.

It opens the Windows® folder where the configuration files are saved:

Choose the configuration file and the Main Screen of the DR60 Configurator will open, with the selected configuration file loaded.

It is also possible to open a configuration file from the Main Screen of the DR60 Configurator, by selecting the option Open Configuration on the menu on the Menu Bar.

3.5 Saving a Configuration File

To save an opened configuration, select the option Save Configuration or Save Configuration As, on the File menu of the Main Screen of the DR60 Configurator.

When saving a configuration, the DR60 Configurator will create three different files:

***.CID file**: saves the communication and recorders configuration. The DR60 uses the SCL schema 3.1 from the IEC 61850 data models;

***.st file**: saves the logic equation and the matrix of I/O and triggering configuration according to the IEC 61131 Structured Text Language (STL).

***extref file**: saves the external references for the GOOSE subscriber configuration.

***xml file**: saves configurations related to DNP3 communication.

3.6 Sending a Configuration File for the Equipment

To send a configuration file to online equipment, select the option Send Configuration, on the Menu Bar.

4 Administrative Tools

The Administrative Tools allows functions as Firmware upgrade, password management, equipment license upgrade and support file download.

Upon clicking the menus, an authentication window will pop up asking for a user and a password to complete the operation

The possible user name and password is:

User	Password
adm	RX8jg3S&mDx

The Administrative Tools menu allows the user to perform the following configurations:

- Access Control – allows changing the password for each kind of user (*cfg*, *adm* and *mon*);
- Firmware Update;
- License Update;
- Support File – Downloads a support file containing internal logs used for diagnosis.

5 Configuration Tabs

5.1 General

The General configuration tab contains information related to the physical device logical node (LPHD) of the DR60.

On this screen, it is shown the information of the respective device:

- Model (CORTEC)
- Vendor (General Electric Company)
- Hardware Version
- Firmware Version
- Serial Number

Moreover, the following parameter can be configured:

- Identifier: Up to 61 characters. Possible characters: a-z, A-Z, a-9, _.
- Location: Up to 255 characters. Possible characters: a-z, A-Z, a-9, _.
- Owner: Up to 255 characters. Possible characters: a-z, A-Z, a-9, _.
- LPHD Prefix: Up to 11 characters. Possible characters: a-z, A-Z, a-9, _.
- Electric Power System: Up to 255 characters. Possible characters: a-z, A-Z, a-9, _.
- Primary Operator: Up to 255 characters. Possible characters: a-z, A-Z, a-9, _.
- Secondary Operator: Up to 255 characters. Possible characters: a-z, A-Z, a-9, _.
- Master Resource Identification: Up to 255 characters. Possible characters: a-z, A-Z, a-9, _.
- Latitude: Possible characters: 0.0-90.0.
- Longitude: Possible characters: 0.0-180.0.
- Altitude: Possible characters: 0.0-10000.0

5.2 Analog



The Analog configuration tab contains configurations related to the analog channels and circuits and it is divided into two sub-tabs: Instrument Transformer (TCTR/TVTR); and Bay Arrangement (MMXU/MMXN).

5.2.1 Bay Arrangement (MMXU/MMXN)

This window allows the configuration of the analog inputs. The configuration includes the circuit description tag, association with physical inputs, nominal values for instrument transformer ratio calculation; activation of: trend measurement calculation, PMU calculation and impedance fault location.

The following configurations are available:

Current and Voltage circuits:

- Nominal Frequency: Selects the nominal frequency of the system between 50 Hz and 60 Hz.
-  Add a new circuit or remove the selected circuit. Selecting a circuit and pressing delete will also remove the circuit.
- Description: Enters a description for the circuit. Up to 256 of any characters is allowed.
- Phase A, Phase B, Phase C and Neutral: Associate each phase of the circuit with its respective physical input.
- Nominal Value: Configures the nominal value of the primary of the instrument transformers. This value is used for transformer ratio calculation and thresholds/triggers.
- Measurement: Shows all the logical nodes associated with the respective circuit and by clicking the sign  the following window will open.

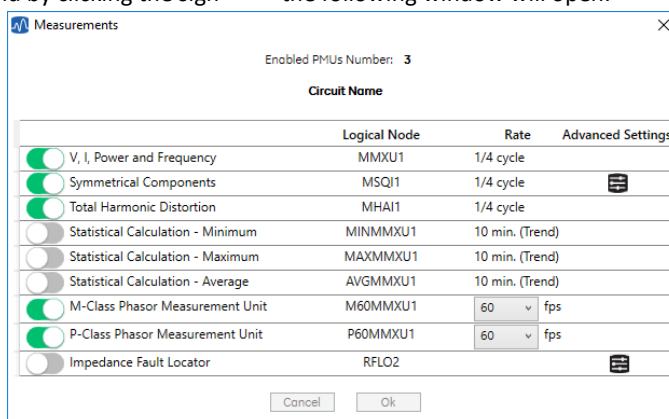

- This window allows the following configuration:
 - Trend calculation activation

- Change Symmetrical Components name in advanced settings tab
- PMU Class M or P activation. The DR60 supports up to 4 PMUs, each class will count as 1 PMU even if they are from the same circuit. When a PMU is activated a logical node associated to it and dataset is automatically created with all the synchrophasor, frequency and rate of change of frequency of the respective circuit. More info on PMU can be found in Chapter 7: PMU.
- Impedance Fault Locator calculation. The line parameters are configured in the advanced settings right on the right side of the window. The fault location is treated according to the IEC 61850 logical node for fault location: RFLO. The fault location can be sent through MMS, Report Control Block or DNP3 by selecting the data attribute *RFLOxFtDiskm.mag.f* within the MX functional constraint.

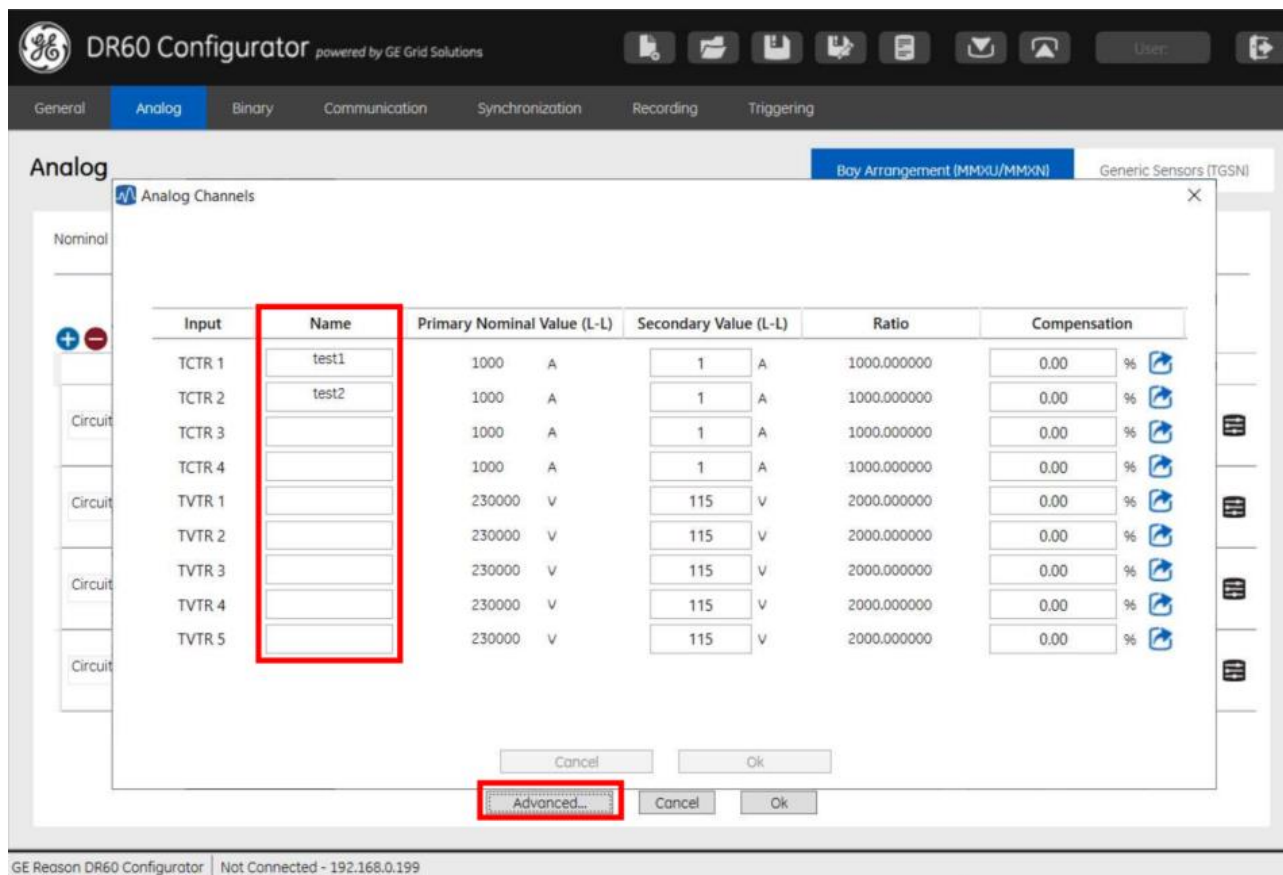

- Advanced: Allows the following configuration.
- Name: Enter name tags for each analog input. Maximum characters: 256. Possible characters: a-z, A-Z, a-9, _.
- Secondary Value: Configures the nominal value of the secondary of the CT/VT. This configuration is only important when using the high accuracy measurement board which can be used for 1 A or 5 A.
- Ratio: Shows the CT/VT ratio according to the primary and secondary values configured.

- Compensation: Inserts a percentage value onto the DR60 reading of that specific analog inputs. Possible characters: -100.0% to 100.0%.

$$\text{Compensation} = \left(\frac{\text{Applied Value}}{\text{Read Value}} - 1 \right) * 100\%$$

For example:

Applied value: 100 V.

Read value: 99 V.

$$\text{Compensation} = \left(\frac{100}{99} - 1 \right) * 100\% = 1,01\%$$

Note:

The names configured for symmetrical components will be considered only for the channel names on PMU function.

5.2.2 Generic Sensor (TGSN) – Transducer inputs

This subtab configures the transducer inputs.

The signal of the transducer (± 10 V or 0-20 mA) is converted into the desired physical measurement using a first order transfer function with the parameters of Scale Factor (A) and offset (B) defined by the user:

$$y = Ax + B$$

where y is the converted value and x is the value read by the DC channel in Volts or Amps. The screen allows the user to configure for each channel: a name, the Scale Factor A , the Offset B and the Unit of the measurement that the transducer represents.

5.3 Binary

This configuration tab contains the parameters to configure the physical binary inputs, enable/disable GOOSE inputs and set their name tags.

5.3.1 Binary Inputs Subtab

The following aspects related to the physical binary inputs are configured on this subtab:

- Level: Selects the voltage level of the binary inputs. There are two options available: 24/48Vdc and 125/250Vdc. The operating changes of each level is

shown in the Technical Specification Chapter. Applying voltage signals incompatible to the Level configuration may damage the inputs.

- GGIO_DIGITAL: Shows the index reference of each binary input (Ind1...Indn).
- Name: Configures the name tags of each binary input. Maximum characters: 12. Possible characters: a-z, A-Z, a-9, _.
- Debouncing Time: The DR60 will only start a record once the binary activation time (i.e. duration of the HIGH signal for the normal polarity channels) has exceeded the debouncing time parameter.
- Polarity: chooses the polarity of each input.
 - Normal: LOW signals are interpreted as LOW signals and HIGH signals are interpreted as HIGH signals.
 - Inverted: HIGH signals are interpreted as LOW signals and LOW signals are interpreted as HIGH signals.



Choose the voltage level of the binary inputs accordingly to the voltage levels applied to them. Choosing 24/48V voltage level and applying higher voltage levels can damage the inputs.

The binary inputs acquisition rate is the same as the configured for the waveform recorder. Then the waveform recorder is not enabled the binary inputs acquisition rate is 256 samples/cycle.

5.3.2 GOOSE Inputs

This subtab allows enabling/disabling and entering a name tag for each GOOSE input. The DR60 can handle up to 256 GOOSE inputs to record, cross-trigger and trigger recorders.

The following parameters are available for configuration:

- GGIO_GOOSE: Enables or disables the corresponding GOOSE input.
- Name: Configures the name tags of each binary input. Maximum characters: 12. Possible characters: a-z, A-Z, a-9, _.

5.4 Communication

This configuration tab contains all the configuration related to communication to other devices, such as: Ethernet and serial ports, PMU streams, GOOSE and Report control blocks, GOOSE subscriber and DNP3 transmission.

5.4.1 Physical

The configuration of the physical communication ports is carried out through this subtab.

Non-Redundant Network mode (None)

In this operation mode each Ethernet port, 1 and 2, have different addresses and it is possible to configure for each of them:

- IP Address
- Network Mask
- Gateway

The Ethernet ports are used to:

Port	Usage
Ethernet 1	Configuration, monitoring, GOOSE publishing / subscription, MMS report control block, firmware upgrade, log and records download.
Ethernet 2	Configuration, monitoring, firmware upgrade, log and records download.

The default settings are:

Default Setting		
Parameter	Ethernet port 1	Ethernet port 2
IP Address	192.168.0.199	192.168.1.199
Network mask	255.255.255.0	255.255.255.0
Gateway	192.168.0.254	192.168.1.254

For the serial ports A (RS232) and B (RS232), the following parameters are configurable:

- Speed;
- Data Bits;
- Parity;
- Stop Bits.

Failover Redundancy mode

In this network redundancy mode only Ethernet interface 1 is configurable and it will operate with all protocols supported by DR60.

In this mode the ethernet interface 1 will be the main interface actively communicating and ethernet interface 2 is in standby monitoring the communication link. If ethernet interface 1 is disconnected, the communication is switched to ethernet interface 2. In this

case the ethernet interface 2 is a redundant or backup link to the network for the other interface.

Once the ethernet interface 1 recovers connection and stays healthy for five minutes, the communication channel is switched back to this interface.

Note:

In failover redundancy PTP is not a valid type of synchronization. The user must choose to operate with synchronization configured for IRIG-B or NO-SYNCH

Note:

In failover PMU configured for multicast will operate only in the active ethernet interface

5.4.2 Datasets

The Dataset section is used to create a dataset for GOOSE or Report publishing. The configurable parameters are described below:

- Datasets buttons:
 - <New>: these buttons creates a new dataset. Clicking on this button, the dataset parameters will appear for editing
 - <Edit>: this button edits a selected pre-existing dataset. Clicking on this button, the dataset parameters will appear for editing
 - <Delete>: this button deletes a selected pre-existing dataset. The DigInput1 dataset cannot be deleted
- Functional Constraint: selects the functional constraint that indicates the possible operating services of a specific DataAttribute. The functional constraints are:
 - ST: Status Information
 - MX: Measurements
 - CO: Control
 - SP: Setting Point
 - SG: Setting Group
 - SE: Setting Group Editable
 - SV: Substitution
 - CF: Configuration
 - DC: Description
 - EX: Extended Definition
- Dataset Name: inserts a name for the new dataset. Maximum characters: 32. Possible characters: a-z, A-Z, a-9, _.
- Description: inserts a description for the new dataset. Maximum characters: 64. Possible characters: except "<" and ">".
- Filter: enables the user to filter the global dataset by DataAttribute names.

Note:

When selecting the data for the dataset, the IEC 61850 name for binary inputs is DIGITALGGIO and the binary outputs is OUTPUTGGIO.

5.4.3 GOOSE Publisher

To publish GOOSE messages grouped in datasets, it is necessary to create a GOOSE Control Block (GCB). In the GOOSE Publisher subtab it is possible to create and edit GOOSE Control Blocks for the GOOSE messages transmission.

Each GCB is associated with one Dataset and the DR60 can send up to 16 GCB.

The configurable parameters are described below:

- GOOSE Control Block Identification
 - Message Name: inserts a name for the GOOSE Control Block. The allowed characters are 0-9, a-z, A-Z and '_'. Maximum characters: 32.
 - Description: inserts a description for the GOOSE Control Block. The not allowed characters are '<' and '>'. Maximum characters: 64.
 - GOOSE ID: inserts an identification for the GOOSE Control Block. The allowed characters are 0-9, a-z, A-Z and '_'. Maximum characters: 129.
 - Dataset: selects the dataset for this GOOSE Control Block. In this field will appear all created datasets.
- Network Settings
 - APP ID: inserts an indication of the message identifier. The identifier must contain four hexadecimal characters. Characters range 0x0 – 0x3FFF.
 - MAC-Address: inserts an indication of the MAC address of the originator to be filtered. The address must be represented as six groups of hexadecimal characters. The allowed characters are 0-9, a-f, A-F and '-'. IEC 61850-8-1 standard recommends the MAC address for GOOSE messages creation as following:
 - The first three octets are 01-0C-CD;
 - The fourth octet must be 01 for GOOSE;
 - Thus, the MAC address must be from 01-0C-CD-01-00-00 to 01-0C-CD-01-01-FF.
 - VLAN-PRIORITY: selects the VLAN priority. Such priority must be a numeric value between 0 and 7.
 - VLAN-ID: inserts the VLAN unique identification. Characters range 0x0 – 0xFFFF.
 - Minimum Time: inserts the maximum delay time allowed for message transmission, after the change of the state. The range is from 1 ms to 60000 ms.

Maximum Time: inserts the source supervision time. If there is none change of state, a message is transmitted in this time. The range is from 4 ms to 60000 ms.

5.4.4 GOOSE Subscriber

The DR60 has 256 virtual GOOSE inputs that can be associated with GOOSE Booleans values.

The configurable parameters are described below:

To associate a GOOSE Control Block with a digital input, do the following:

- 1 Load the SCL file from the IED sending the messages clicking "Add SCL File".
- 2 On the right side, select the GOOSE Boolean that the DR60 shall subscribe to, on the right side select the GOOSE input that will be associated with that GOOSE boolean. Only the GOOSE inputs enabled in the Binary configuration tab will be displayed.
- 3 Click the ">>" button to perform the association and "<<" to undo it.

Note:

You should subscribe to GOOSE messages within the range of allowed MAC Addresses from **01-0C-CD-01-00-00** to **01-0C-CD-01-FF-FF**.

5.4.5 Reports

This screen allows the user to configure the MMS Report Control Blocks (RCB). The Report Control Block sends internal variables grouped on a datasheet to the supervisory system. Each RCB is associated to one Dataset and the DR60 can send up to 15 buffered or unbuffered Report Control Blocks.

The configurable parameters are described below:

Report Control Block Identification and data

- Message Name: inserts a name for the GOOSE Control Block. The allowed characters are 0-9, a-z, A-Z and '_'. Max characters: 32.
- Description: inserts a description for the GOOSE Control Block. The not allowed characters are '<' and '>'. Max characters: 64.
- Report ID: Optional RCB identifier. The allowed characters are 0-9, a-z, A-Z and '_'. Max characters: 74.
- Dataset: selects the dataset for this Report Control Block. All the created datasets will be listed here.

Options

- Buffered: internal events (caused by trigger options data-change, quality-change, and data-update) issue immediate sending of reports or buffer the events (to some practical limit) for transmission, such that values of data object are not lost due to transport flow control constraints or loss of connection;
- Buffered Time: specifies the time interval in milliseconds for the buffering of internal notifications caused by data-change (dchg), quality-change (qchg), dataupdate (dupd) by the BRCB for inclusion into a single report;
- Upon receipt of the first set of internal notification of events of the referenced dataset, the BRCB starts a timer of the duration buffer time. When the timer expires, the BRCB combines all internal notifications that have been received during the time interval into a single report. The next internal notification following the timer expiration signals the new start of that timer. Range: 1 – 1000 ms. Step 1 ms;

- Indexed: When checked the report control block instance names are created from the RCB name, followed by an index number from 01 up to maximum 15;
- Max Instances: To allow multiple clients to receive the same values of data object, multiple instances of the report control classes shall be made available. Once a report control block is reserved, by a specific client, no other client shall have access rights to set the control block attributes. Up to 16 instances can be configured.

Trigger Options: Specifies the trigger conditions which will be monitored by this BRCB. The following values are defined:

- Data Change (dchg); relates to a change in a value of a DataAttribute representing the process-related value of the data object;
- Quality Change(qchg); relates to a change in the quality value of a DataAttribute;
- Data Update (dupd): relates to a freeze event in a value of a DataAttribute representing a freeze value of the data object (for example, frozen counters) or to an event triggered by updating the value of a DataAttribute. Data-update trigger condition may be used to issue sending a report or storing a log entry into a log when a value of a DataAttribute has updated. Updating may mean that the value has changed or has been “overwritten” with the same value as before. The dupd trigger condition can be used as a trigger for statistics values that may be calculated and updated on a periodic base. Independently of whether the statistics value has changed or not, the value will be reported or logged;
- General Interrogation: After a request for General Interrogation the BRCB starts the interrogation process and create a report that includes all DataAttribute values of the referenced dataset;
- Integrity: When integrity reports are enabled, the BRCB shall be notified each time the value of the time as specified in Integrity Period has expired. The BRCB then builds a report with the values of all members of the referenced data-set. Range: 1 – 1000 ms. Step 1 ms.

Note: The general-interrogation is initiated by the client. The integrity report, which also transmits all values of a data set, is initiated by the BRCB.

Optional Fields:

- Sequence Number: Includes the SqNum in the report. The attribute SqNum specifies the sequence number for each BRCB that has report enable set to TRUE. This number is incremented by the BRCB for each report generated and sent;
- Dataset name: Includes DatSets in the report;
- Data Reference: Includes the DataRef in the report;
- Buffer Overflow: Includes the BufOvfls in the report. The parameter BufOvfl indicates to the client that entries within the buffer may have been lost;

- Report Time Stamp: Includes the time stamp in the report;
- Entry ID: Includes EntryID in the report;
- Configuration Revision: Includes the ConfRev in the report. The attribute ConfRevshall represent a count of the number of times that the configuration of the data-set referenced by DataSet has been changed.

Note: RMS values and frequency values are calculated and made available for MMS communication every $\frac{1}{4}$ cycle.

5.4.6 C37.118.2-2011 (PMU)

This tab allows the configuration of the communication parameters of the PMU streams. For each of the 4 separate streams the following configuration is available:

- **Enable:** Enables the transmission of the respective frame;
- **ID:** PMU ID according to C37.118-2011. The PMU ID code is set to uniquely associate the synchrophasor values to the PMU responsible for producing them. The ID ranges from 1 to 65534;
- **Dataset:** Associates the PMU stream with a PMU dataset. The PMU dataset is created automatically when the PMU is activated for a circuit in the **Analog** configuration tab and it can be edited in the **Communication>Dataset** tab;
- **Frame Rate:** Selects the frame rate for the respective stream. 60 fps at 60 Hz and 50 fps at 50 Hz are available;
- **Communication Mode:** Configures the communication or operation mode of the stream. The configurations available are: Commanded, Spontaneous Unicast or Spontaneous Multicast;
- **PMU Frames:** Enable or disable which C37.118.2-2011 frames (HDR, CFG1, CFG2, CFG3) will be sent spontaneously depending on the communication mode;
- **Protocol:** Chooses between the UDP/IP or TCP/IP transmission protocols;
- **Source Port:** Chooses the source port of the respective stream. Each stream needs to have an exclusive port number. Multiple streams cannot be sent with the same port number;
- **Destinations Address:** Configure the destination IP address and port number for the spontaneous transmissions;
- **Output Interface:** In case the destination address is not in the same submask as one of the ethernet ports, the streams will be sent through the Ethernet 1 interface.

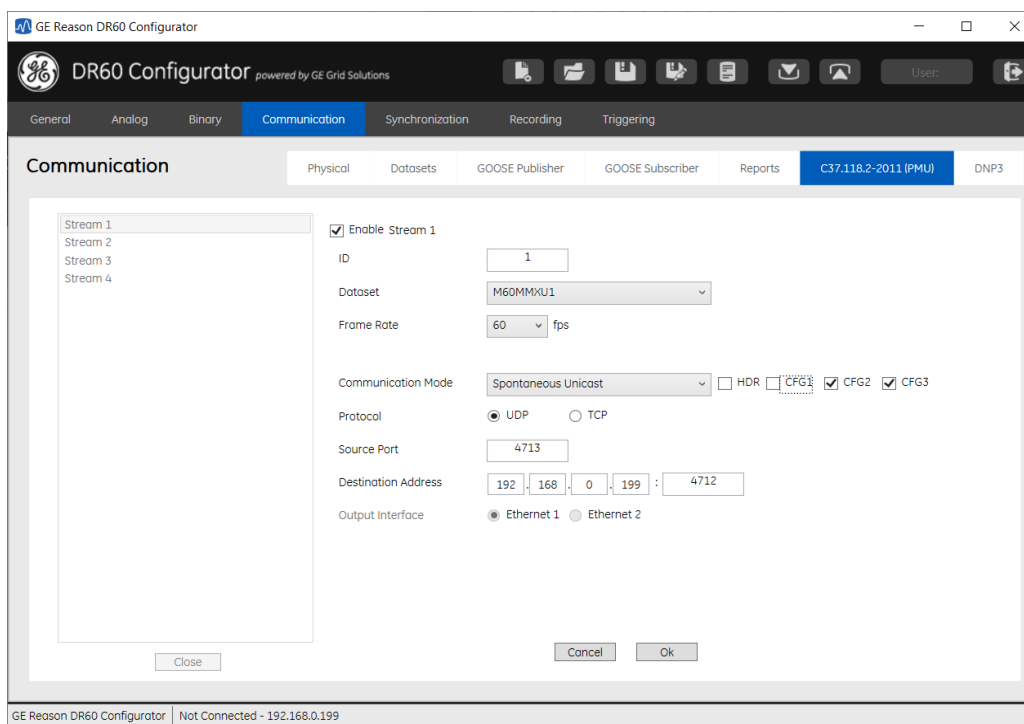

5.4.7 DNP3

The DR60 provides DNP3 implementation level 2 for outstation equipment via both Ethernet or serial communication.

This tab allows the configuration of the communication parameters of the DNP3 streams. The following configuration parameters are available:

- Enabled: Turn on or off the DNP3 streaming.
- DNP3 Communication: Selects the physical interfaces that will send DNP3. Ethernet, Serial port 1 or serial port 2.
- Master IP Address: IP address of the equipment reading the DNP3.
- Outstation Address: DNP3 address of the DR60 being configured. Range 0 to 65534.
- Outstation port: Port number for the DR60 being configured. 20000 is the default and the port number registered for DNP3 use with the IANA (Internet Assigned Numbers Authority).
- Application Timeout: The timeout for an application layer confirmation in seconds. Range 0,01 to 40 s.
- Link Layer Timeout: The timeout for a data link layer confirmation in seconds. Range 0,01 to 40 s.
- Enable Unsolicited Reporting:
 - Server address to report to: DNP3 address of the server (master).
- Class 1, 2, 3
 - Max Delay: Maximum time the outstation waits until sending the data pertaining to each class in case no data state change or DNP3 threshold is exceeded.

- Max Events: Maximum number of events that can be buffered for each class. Range 1 to 200.
- Mask: Enables the transmission of the respective DNP3 class.
- Object Variation: Defines the variation of the respective object to be reported when the master does not request any specific type.
 - Object 1 – Binary Inputs - Options: 1 – With status; 2 – Without status
 - Object 2 – Binary Input Event - Options: 1 – Without timestamp; 2 – With timestamp; 3 – With relative timestamp
 - Object 30 – Analog Input - Options: 1 – (32) Integer; 2 – (16) Integer; 3 – (32) Integer without flag; 4 – (16) Integer without flag
 - Object 32 – Analog Input Event - Options: 1 – (32) Integer without timestamp; 2 – (16) Integer without timestamp; 3 – (32) Integer with timestamp; 4 – (16) Integer with timestamp

Input Selection

- Binary
- Analog
 - Scale: Scale factor that multiplies the analog measurement
 - Deadband: An event is triggered when the Analog input changes an amount greater than the deadband value. A Deadband of zero permits any change in the analog input value to generate an event, and a Deadband of full range of the variable prevents generation of an event

Note: Only float measurement marked with the suffix .f|MX are able to be transmitted via DNP3.

5.5 Synchronization

5.5.1 Synchronization

The DR60 supports time synchronization with PTP IEEE1588v2 and demodulated IRIG-B004. It is also possible to configure the DR60 to work with no time sync, just with the internal clock.

The following parameters are found on this configuration tab:

Time source:

- IRIG-B: sets the DR60 to be synchronized with IRIG-B. No further configuration is necessary.
- PTP: sets the DR60 to be synchronized with PTPv2. The PTP configuration presents the following parameters:

5.5.2 PTP Configuration

The PTPv2 synchronization source presents the following parameters:

- Holdover Time: Period during which the DR60 can maintain the synchronization quality without an external sync reference, thanks to drift of the internal clock. Range: 5 – 60s.
- Network Interface: Choses the Ethernet port used for the PTP sync.
- Profile: Choses between the PTP profiles: Power IEEE C37.238/2011, P2P default and Custom.
- Domain Number: A PTP domain is a collection of one or more PTP subdomains. A subdomain is a logical grouping of 1588 clocks that synchronize to each other using the PTP protocol, but that are not necessarily synchronized to PTP clocks in another PTP subdomain. Subdomains provide a way of implementing disjoint sets of clocks, sharing a common network, but maintaining independent synchronization within each set. The domain number can be set as 0, 1, 2 or 3.
- Network Protocol: allows the user to choose between the UDP protocol and Ethernet layer 2.
- VLAN ID and Priority: Define VLAN parameters according to IEEE 802.1Q.
- Operation Mode: Two options are available:
 - Two-step: In two-step-mode the master sends a synchronization message – SYNC message – with an estimated value of the time cyclically to the connected slaves. Parallel to this, the time at which the message leaves the sender is measured as precisely as possible. The master then sends this actual exact transmission time of the corresponding sync message to the slaves in a second message - follow-up message. These also measure the reception time of these messages as exactly as possible and can correct the correction value (offset) to the master from it. The slave clock is then corrected by this offset. If the transmission line were to have no delay, both clocks would be synchronized.
 - One-step: The master sends a synchronization message – SYNC – message with the precise value of the time cyclically to the connected slave. Other than in two-step-mode, the precise time is inserted into the SYNC message “on-the-fly” by the hardware. No FOLLOWUP – messages are needed in this mode. The calculation of the offset is the same as in two-step-mode.
- Delay Mechanism: Two delay mechanism are defined:
 - End-to-end: Only measures the time taken for a PTP event message to transit the bridge and provide this information to the receiving clocks in the correction field of the PTP message. In this mode the propagation delay of the link connected to the port is not corrected
 - Peer-to-peer: Use the peer delay mechanism for the delay measurement. In addition to providing PTP event transit time information, also provides corrections for the propagation delay of the link connected to the port receiving the PTP event message

The peer delay mechanism measures the port to port propagation delay time between two directly connected ports sharing the same communication technology.

- Grandmaster Priority: Is an administratively assigned precedence hint used by the Best Master Clock algorithm (BMC) to help select a *grandmaster* for the PTP domain. The range is from 0 to 255.
- Announce Receipt Timeout: configures the interval between PTP announce messages on an interface or the number of PTP intervals before a timeout occurs on an interface.

When configuring PTP, the first point is to select which PTP profile, or which common parameters, will be used along with all PTP devices. The DR60 has three options to be selected as profile:

- Power Profile – IEEE C37.238/2011: this profile has some fixed parameters defined by the standard and some configurable parameters defined by the user.

The configurable parameters for Power Profile are:

Domain number;
VLAN ID and Priority;

The fixed parameters are:

Network Protocol: Ethernet Level 2;
Operation Mode: One step;
Delay Mechanism: Peer-to-peer;
Grandmaster Priority: #1 255; #2 255;
Announce Receipt Timeout: 3

- The CUSTOM profile has all its parameters opened for user configuration.
- The P2P Default profile is partially configurable. The fixed parameters are:

Domain number: 0;
Grandmaster Priority: #1 128; #2 128

Configurable parameters are:

Domain number:
Operation mode:
Delay Mechanism:
GRANDMASTER PRIORITY:
Announce Receipt Timeout:

- Internal clock: sets the DR60 to work with no external source of sync. The internal clock configuration is carried out through the web interface described in the Monitoring Web Interface section.

5.5.3 Ethernet Network Synchronism Recommendations

In order to obtain the best synchronism performance in an Ethernet network, the following configuration is recommended.

- PTP Power Profile (IEEE C37.238);
 - Delay mechanism: Peer-to-Peer (P2P)
 - This means that ALL equipment (Switches, GPS clocks, DR60s, Relays, Bay Controllers, and so on) must be PTP-aware.
 - Mapped as Ethernet (Layer 2 – L2) messages
 - This means that ALL equipment (Switches, DR60s, Relays, Bay Controllers, and so on) must be PTP-aware.
 - One-step (preferred) or Two-step operation
 - Time is stamped preferentially at hardware.
- Max number of hops: 16
- Max error introduced by hop: 50ns
- Max error in slave: 1us
- Multicast filtering or VLAN segregation shall be configured in the managed switches, otherwise the DR60 might present instable and undesirable behavior in its applications and synchronism.

5.6 Recording

This configuration tab options to enables/disables the waveform, disturbance, continuous disturbance and SOE recorder and their parameters.

The following configuration parameters are available:

Waveform recorder: Enables/disables the recorder.

- Pre trigger time: configures the recording time duration before the waveform recorder trigger.
- Post trigger time: configures the recording time duration after threshold is activated.
- Maximum time: configures the maximum time of the record.
- Disable for: disables temporarily the recorder if various triggers repeat within a period of time.
- Sample rate: selects the sampling rate of the recorder (256 or 512 ppc).
- Retrigger: Enables and disables the retrigger. Refer to Records Chapter for information on retrigger functioning.
- Periodic Trigger: Allows configuring the recorder to trigger at preset periodic intervals

Disturbance recorder: Enables/disables the recorder.

- Pre trigger time: configures the recording time duration before the disturbance recorder trigger.
- Post trigger time: configures the recording time duration after threshold is desensitized.
- Maximum time: configures the maximum time of the record.

- Disable for: disables temporarily the recorder if various triggers repeat within a period of time.
- Sample rate: selects the sampling rate of the recorder (1, 2 or 4 ppc).
- Select Measures: selects which measurement values will be recorded. Up to 128 measurements can be recorded. The full list of measurements is found in Chapter Records.
- Retrigger: Enables and disables the retrigger. Refer to Records Chapter for information on retrigger functioning.
- Periodic Trigger: Allows configuring the recorder to trigger at preset periodic intervals

The ranges and steps for the pre, post and maximum times configuration are shown in the Records Chapter.

Continuous Disturbance Recorder: Enables/disables the recorder.

- Aggregation Period: Configures the duration of each record. A new record will be created every time the aggregation period elapses. Range: 10.0 to 60.0 minutes.
- Sample rate: selects the sampling rate of the recorder (1, 2 or 4 ppc).
- Select Measures: selects which measurement values will be recorded. Up to 128 measurements can be recorded. The full list of measurements is found in Chapter Records.

Trend Recorder

- Calculation Period: Period of time used for maximum, minimum and average calculation. Range: 1, 5, 10, 15, 20, 30 and 60 min.
- Aggregation Period: Duration of the record. Range 1 to 24 h.
- Select Measures: Selection of the measurement to be recorded.

SOE Recorder: Enables/disables the recorder.

- Aggregation Period: Configures the duration of each record. A new record will be created every time the aggregation period elapses. Range: 1 to 1440 minutes.

5.7 Triggering

The Triggering configuration tab allows the configuration of the parameters used as thresholds to trigger the waveform and disturbance recorders.





5.7.1 Thresholds

This screen allows the configuration of thresholds associated with measured and calculated values (from the analog channels) that once exceeded can cause the DR60 recorders trigger.

Following parameters can be set for each defined threshold:

















Parameters set for each defined threshold		
Parameter	Range	Step
Hysteresis	0 ... 20 %	0.1 %
Hold time	0 ... 1000 ms	1 ms















The thresholds are displayed side by side to easy and quick configuration. Upper and lower thresholds are represented by the following signs:

Threshold	Sign	Example
Upper (Over)		Over Frequency – F  (Hz)
Lower (Under)		Under Frequency – F  (Hz)

Blank threshold will not be processed and will not trigger the recorder.

Below is the list of all possible thresholds:

Fundamental Measures		Description	Type
P _{3φ}	(MW)	Total active power	 and 
Q _{3φ}	(MVA _r)	Total reactive power	 and 
S _{3φ}	(MVA)	Total apparent power	 and 
F	(Hz)	Frequency	 and 
V _p	(PU)	Phase voltages RMS	 and 
V _N	(PU)	Neutral voltages RMS	 and 
I _p	(kA)	Phase currents RMS	 and 
I _N	(kA)	Neutral currents RMS	 and 

Basic Measures		Description	Type
V1	(PU)	Positive sequence voltage	 and 
V2	(PU)	Negative sequence voltage	 and 
V0	(PU)	Zero sequence voltage	 and 
I1	(kA)	Positive sequence current	 and 
I2	(kA)	Negative sequence current	 and 
I0	(kA)	Zero sequence current	 and 
THD _{VP}	(%)	Phase voltage total harmonic distortion	 and 

THD _{VN}	(%)	Neutral voltage total harmonic distortion	▲ and ▼
THD _{IP}	(%)	Phase current total harmonic distortion	▲ and ▼
TDH _{IN}	(%)	Neutral current total harmonic distortion	▲ and ▼

Derivative Measures		Description	Type
P _{3Φ}	(MW/s)	Total active power	▲
Q _{3Φ}	(MVar/s)	Total reactive power	▲
S _{3Φ}	(MVA/s)	Total apparent power	▲
F	(Hz/s)	Frequency	▲
V _P	(PU/s)	Phase voltages RMS	▲
V _N	(PU/s)	Neutral voltages RMS	▲
I _P	(kA/s)	Phase currents RMS	▲
I _N	(kA/s)	Neutral currents RMS	▲

Single-phase Measures		Description	Type
F	(Hz)	Frequency	▲ and ▼
V	(PU)	Voltage	▲ and ▼
I	(kA)	Current	▲ and ▼
P	(MW)	Active Power	▲ and ▼
Q	(MVar)	Reactive Power	▲ and ▼
S	(MVA)	Apparent Power	▲ and ▼
PF		Power Factor	▲ and ▼
THD _V	(%)	Voltage Total Harmonic Distortion	▲ and ▼
THD _I	(%)	Current Total Harmonic Distortion	▲ and ▼

Single-phase Measures (Derivative)		Description	Type
F	(Hz/s)	Frequency	▲
V	(PU/s)	Voltage	▲
I	(kA/s)	Current	▲
P	(MW)	Active Power	▲
Q	(MVar)	Reactive Power	▲
S	(MVA)	Apparent Power	▲
PF/s		Power Factor	▲
THD _V	(%/s)	Voltage Total Harmonic Distortion	▲
THD _I	(%/s)	Current Total Harmonic Distortion	▲

Other Measures		Description	Type
PF _{AVG}		Average Power Factor	▲ and ▼

V_{AB}	(PU)	Phase-to-phase Voltage AB	▲ and ▼
V_{BC}	(PU)	Phase-to-phase Voltage BC	▲ and ▼
V_{CA}	(PU)	Phase-to-phase Voltage CA	▲ and ▼
P_P	(MW)	Phase Active Power	▲ and ▼
P_N	(MW)	Neutral Active Power	▲ and ▼
Q_P	(MVar)	Phase Reactive Power	▲ and ▼
Q_N	(MVar)	Neutral Reactive Power	▲ and ▼
S_P	(MVA)	Phase Apparent Power	▲ and ▼
S_N	(MVA)	Neutral Apparent Power	▲ and ▼
PF_P		Phase Power Factor	▲ and ▼
PF_N		Neutral Power Factor	▲ and ▼
VP_P	(PU)	Phase Voltages Phasor	▲ and ▼
VP_N	(PU)	Neutral Voltages Phasor	▲ and ▼
IP_P	(kA)	Phase Currents Phasor	▲ and ▼
IP_N	(kA)	Neutral Currents Phasor	▲ and ▼

Note: The derivative thresholds are calculated within a window of 1 cycle.

Description of the Threshold subtab shown in the figure below.

A To add a new Threshold, click the + sign on the left side of the screen.

B To remove a threshold line, select the line by clicking any of the parameters of the corresponding circuit and then hit Delete on the computer keyboard.

Figure below shows the two point above mentioned.

The screenshot shows the GE Reason DR60 Configurator interface. The 'Triggering' subtab is selected, displaying a table of available thresholds. The table has columns for various parameters: P₂₀ (MW), P₃₀ (MW), Q₂₀ (MVar), Q₃₀ (MVar), S₂₀ (MVA), S₃₀ (MVA), F (Hz), V_r (PU), V_n (PU), I_r (kA), and I_n (kA). A '+' sign is visible on the left side of the table, and a blue box labeled 'B' highlights a row in the table.

5.7.2 Equations

This subtab allows the configuration of logic equation using thresholds, binary inputs, GOOSE inputs and other equations as operands.

The list below shows the logic operator and their syntax:

- NOT: Not (operand)

- RISE: Rise (operand)
- FALL: Fall (operand)
- AND: operand AND operand
- OR: operand OR operand
- XOR: operand XOR operand
- LATCH (SET/RESET): Latch (set operand, reset operand)

5.7.3 Matrix

The matrix is used to assign which signals will close the binary outputs and trigger the waveform and/or disturbance recorder.

Thresholds, binary inputs, GOOSE inputs and equations can be configured to close the binary outputs and trigger the waveform and disturbance recorders.

To associate the variables (thresholds, binary inputs, GOOSE inputs and equations) with the triggers of binary outputs, double click the cell that intersects the variable row with the binary output or trigger.

Clicking the clock sign next to the binary outputs number allows the configuration of pickup and drop-off timer for the respect binary output operation. Within the timer setting, the parameter Timer Value (ON) means that the signal causing the respective output to close needs to stay ON during, at least, the time configured. The parameter Timer Value (OFF), correspondingly, means that the signal causing the respective output to close needs to stay OFF during, at least, the time configured. The diagram below exemplifies the functioning of the timers.

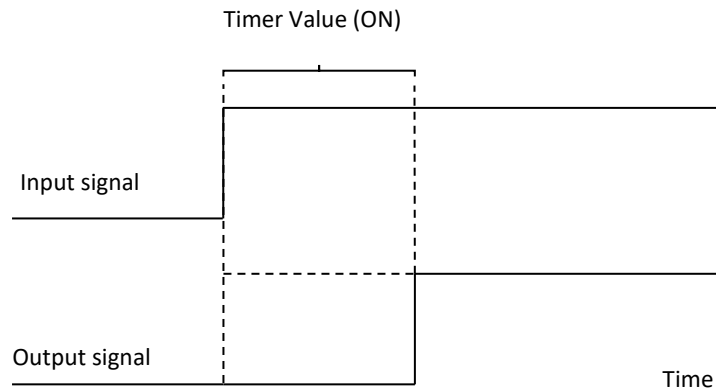

Timer Value (ON) diagram

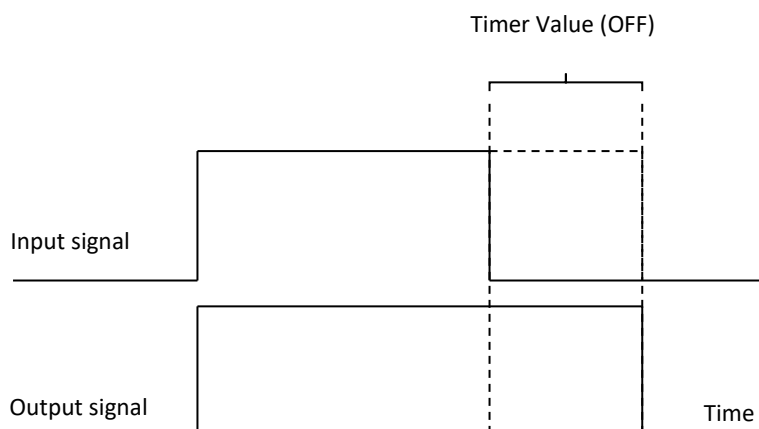

Timer Value (OFF) diagram

Binary Inputs can trigger the recorders using the following types of binary signal transitions:

- Fall - "High" to "Low" transition (also called falling edge)
- Rise - "Low" to "High" transition (also called rising edge)
- Both - "Low" to "High" and "High" to "Low" transitions
- Direct - "Low" to "High" level transition

6 Monitoring and Web Interface

The DR60 has a web interface with monitoring options. To access the web interface type in the DR60 IP Address using the Mozilla Firefox or Google Chrome browser from computers, cellphones or tablet.

The default IP Addresses are shown in the Communication Chapter. In case the default IP address has been changed and the user cannot recall it, use the IP Scanning tool in the DR60 Configurator communication menu in order to recover it refer to section (IP Address Scanning in the Configuration Chapter.

The DR60 web interface allows the user to:

- Monitor real time calculated and measured values
- Verify device information as serial number, CORTEC and others
- Verify the device status
- Check information on recorders and the created COMTRADE files. The table below shows the available data to monitor on this page.
- Start a manual trigger
- Change the internal clock time

The DR60 also have an MMS server that can be access by IEC 61850 MMS clients to monitor its internal variables, such as: binary I/O status, measurements, alarms etc. The DR60 can support up to 20 MMS clients. The web interface connects as a MMS client (counting as 1 clients per web interface).

Records page data:

Item	Description
Recorder status	Shows if the respective recorder is enabled or disabled
Recording made	Shows that a trigger was generated*
Fault number	Shows how many triggers were generated**
Memory used	Shows the percentage usage of the respective recorder
Pre-trigger time	Shows the pre-trigger time configured
Post-trigger time	Shows the post-trigger time configured
Maximum record time	Shows the maximum recorder time configured
Retrigger enabled	Shows if the retrigger is enabled or disabled
Sample rate	Shows the configured sampling rate for the respective recorder
Inhibition time	Shows the duration that the trigger generation will be disabled***
Inhibition count	Shows how many consecutive triggers within the inhibition time window are needed to enable the trigger inhibition***
Inhibition window	Shows the time that is needed to enable the trigger inhibition***

*This information is 1 when record is generated and 0 during the record generation.

**The counter restarts when the equipment reboots or a new configuration is sent.

***Parameter configured in configuration tab Recording> Disable for.

Note: To avoid glitches and poor web interface performance it is recommended not to have more than three simultaneous web interface connections to the same DR60.

7 Alarm and Warning Reporting

The DR60 can report alarm/warning using the dry contact normally closed relay or via communication protocols (MMS and GOOSE).

The alarm events, in addition to the protocol transmission, will also operate the IN SERVICE normally closed dry contact relay.

Warning events can only be sent via protocol.

The table also presents the IEC 61850 data name/address to be used when creating a dataset for these alarms/warnings as presented in section 2.1.

DR60

Digital Recorder

Chapter 5: Records

This chapter details all types of registers created by the DR60.

1 Waveform Records

The waveform recorder registers the actual voltage or current signal being applied to the analog channels. It captures the instantaneous values of the signal at a configurable sampling rate of 256 or 512 samples/cycle.

The condition that initiated the waveform recording is called trigger. A trigger happens whenever there's a violation of digital (binary or GOOSE inputs) or analog thresholds. Other ways to create waveform records are by cross-trigger signal coming from another recorder or by a manual trigger.

1.1 Recorded Values

The following values are recorded by the waveform recorder:

- Voltage waveform of all voltage circuits (A, B, C, and N);
- Current waveform of all current circuits (A, B, C, and N);
- Transducer waveform of all transducer channels;
- Binary Inputs;
- Binary Outputs;
- GOOSE Inputs.

1.2 Recording Times by Trigger

The following durations are configurable in the waveform recorder:

Parameter	Range at 256 ppc	Range at 512 ppc	Increment
Pre Trigger time	0.0 ... 30.0 s	0.0 ... 15.0	0.1 s
Post Trigger time	0.0 ... 30.0 s	0.0 ... 15.0	0.1 s
Maximum Record time	1.0 ... 60.0 s	1.0 ... 30.0	0.1 s

The Maximum Record time configures the maximum duration that the register can reach. If consecutive re-triggers or a sustained fault happens, the Maximum Record time establishes the limit of time that the COMTRADE file will register. The maximum duration of the fault record is 30 seconds.

1.3 Sampling Rate

The wave recorder sampling rate is user-selectable between 256 and 512 samples/cycle. The size of the records is proportionally affected. Both analog and digital inputs are recorded at the same sampling rate depending on the type of recorder, i.e. waveform fault records: 256 and 512 samples/cycle and Disturbance and continuous disturbance recorder: 1, 2 or 4 samples/cycle.

1.4 Trigger Burst Limiter

There is a user-configurable trigger burst limiter for the waveform recorder. The burst limiter is based on the number of triggers time interval (both parameters are user-configurable). When the limit is exceeded, recording will be disabled for a period defined by the user. This configuration aims to prevent excessive processing demand from jeopardizing the device functioning.

Parameter	Allowed values	Increment
Number of triggers	1 ... 16	1
Time interval	1 ... 60 s	1 s
Disabling time	1 ... 30 min	1 min

2 Re-trigger and Record Concatenation

In case a consecutive event takes place and triggers the recorder within 1 second after the post-fault time of the prior event, then the DR60 concatenates both records and stores it in a single COMTRADE file.

In the figure below, the second trigger happens within the 1 second time window, which makes the DR60 combine both events in a single file. The re-trigger can be enabled or disabled via configuration software.

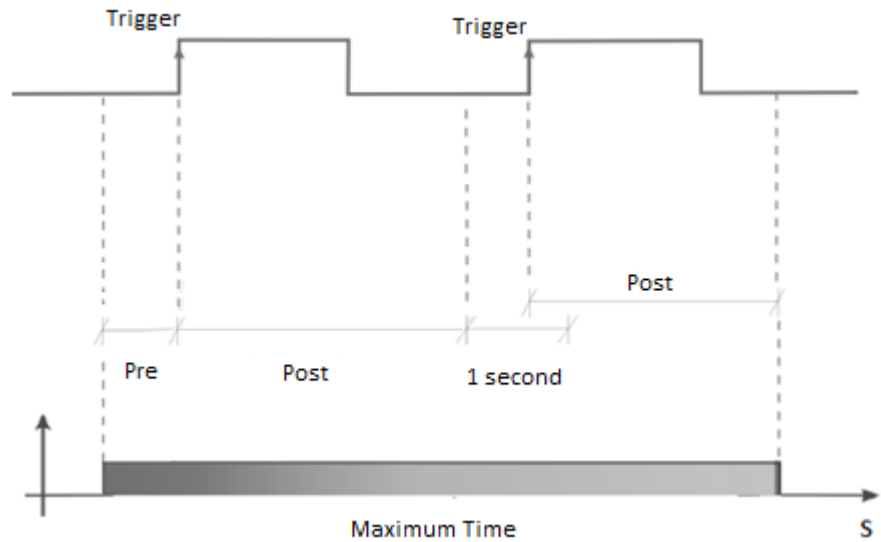

3 Disturbance and Continuous Disturbance Records

The disturbance recorder registers calculated values derived from the current and voltage signal being applied to the analog channels.

Disturbance records are divided into two types depending on how the register recording is initiated:

- Continuously:

Derived measurements are continuously recorded. A new record is created at each hour rollover. The record size depends on the number of derived measurements selected by the user. The record can contain up to 128 measurements. The continuous disturbance recorder has a parameter called Aggregation Period (10,0 – 60,0 min, 0,1 step). The recorder will create a new record every time the Aggregation Period has elapsed.

- By trigger:

The disturbance recorder can be triggered by a Boolean equation, by a cross-trigger signal of another recorder, by a manual trigger using the Web Interface, or by the triggering of the fault recorder. It is possible to select the derived quantity of triggered disturbance records. If the quantities are not manually selected, the record will consist of all the quantities available for measurement. The record size depends of the number of derived measurements selected by the user.

Continuous and triggered disturbance records share the same mass storage area.

3.1 Recorded Values

The table below presents all the available measurements from where the disturbance register can record up to 128. Some measurements are divided into 3 different types for easy configuration. The intention is to divide the measurements into classes of “importance” and they are: Fundamental, Basic and Other measurements:

	Measurement	IEC 61850 Reference
Type	MMXU	
Fundamental	Total active power	MET/MMXU.TotW.mag.f
Fundamental	Total reactive power	MET/MMXU.TotVAr.mag.f
Fundamental	Total apparent power	MET/MMXU.TotVA.mag.f
Others	Average power factor	MET/MMXU.TotPF.mag.f
Fundamental	Frequency	MET/MMXU.Hz.mag.f
Others	AB Line voltage (magnitude)	MET/MMXU.PPV.phsAB.cVal.mag.f
Others	BC Line voltage (magnitude)	MET/MMXU.PPV.phsBC.cVal.mag.f
Others	CA Line voltage (magnitude)	MET/MMXU.PPV.phsCA.cVal.mag.f
Fundamental	A Voltage (RMS)	MET/MMXU.PhV.phsA.cVal.mag.f
Fundamental	B Voltage (RMS)	MET/MMXU.PhV.phsB.cVal.mag.f
Fundamental	C Voltage (RMS)	MET/MMXU.PhV.phsC.cVal.mag.f
Fundamental	A Current (RMS)	MET/MMXU.A.phsA.cVal.mag.f
Fundamental	B Current (RMS)	MET/MMXU.A.phsB.cVal.mag.f
Fundamental	C Current (RMS)	MET/MMXU.A.phsC.cVal.mag.f
Others	A Phase active power	MET/MMXU.W.phsA.cVal.mag.f
Others	B Phase active power	MET/MMXU.W.phsB.cVal.mag.f
Others	C Phase active power	MET/MMXU.W.phsC.cVal.mag.f
Others	A Phase reactive power	MET/MMXU.VAr.phsA.cVal.mag.f
Others	B Phase reactive power	MET/MMXU.VAr.phsB.cVal.mag.f
Others	C Phase reactive power	MET/MMXU.VAr.phsC.cVal.mag.f
Others	A Phase apparent power	MET/MMXU.VA.phsA.cVal.mag.f
Others	B Phase apparent power	MET/MMXU.VA.phsB.cVal.mag.f
Others	C Phase apparent power	MET/MMXU.VA.phsC.cVal.mag.f
Others	A Phase power factor	MET/MMXU.PF.phsA.cVal.mag.f
Others	B Phase power factor	MET/MMXU.PF.phsB.cVal.mag.f
Others	C Phase power factor	MET/MMXU.PF.phsC.cVal.mag.f
Others	A Current Phasor (magnitude)	MET/MMXU.A.phsA.instCVal.mag.f
Others	B Current Phasor (magnitude)	MET/MMXU.A.phsB.instCVal.mag.f

Others	C Current Phasor (magnitude)	MET/MMXU.A.phsC.instCVal.mag.f
Others	A Current Phasor (angle)	MET/MMXU.A.phsA.instCVal.ang.f
Others	B Current Phasor (angle)	MET/MMXU.A.phsB.instCVal.ang.f
Others	C Current Phasor (angle)	MET/MMXU.A.phsC.instCVal.ang.f
Others	A Voltage Phasor (magnitude)	MET/MMXU.PhV.phsA.instCVal.mag.f
Others	B Voltage Phasor (magnitude)	MET/MMXU.PhV.phsB.instCVal.mag.f
Others	C Voltage Phasor (magnitude)	MET/MMXU.PhV.phsC.instCVal.mag.f
Others	A Voltage Phasor (angle)	MET/MMXU.PhV.phsA.instCVal.ang.f
Others	B Voltage Phasor (angle)	MET/MMXU.PhV.phsB.instCVal.ang.f
Others	C Voltage Phasor (angle)	MET/MMXU.PhV.phsC.instCVal.ang.f
	MSQI	
Basic	Current positive sequence (magnitude)	MET/MSQI.SeqA.c1.instCVal.mag.f
Basic	Current positive sequence (angle)	MET/MSQI.SeqA.c1.instCVal.ang.f
Basic	Current negative sequence (magnitude)	MET/MSQI.SeqA.c2.instCVal.mag.f
Basic	Current negative sequence (angle)	MET/MSQI.SeqA.c2.instCVal.ang.f
Basic	Current zero sequence (magnitude)	MET/MSQI.SeqA.c3.instCVal.mag.f
Basic	Current zero sequence (angle)	MET/MSQI.SeqA.c3.instCVal.ang.f
Basic	Voltage positive sequence (magnitude)	MET/MSQI.SeqV.c1.instCVal.mag.f
Basic	Voltage positive sequence (angle)	MET/MSQI.SeqV.c1.instCVal.ang.f
Basic	Voltage negative sequence (magnitude)	MET/MSQI.SeqV.c2.instCVal.mag.f
Basic	Voltage negative sequence (angle)	MET/MSQI.SeqV.c2.instCVal.ang.f
Basic	Voltage zero sequence (magnitude)	MET/MSQI.SeqV.c3.instCVal.mag.f
Basic	Voltage zero sequence (angle)	MET/MSQI.SeqV.c3.instCVal.ang.f
	MHAI	
Basic	Current total harmonic distortion	MET/MHAI.ThdA.phsA.cVal.mag.f
Basic	Current total harmonic distortion	MET/MHAI.ThdA.phsB.cVal.mag.f
Basic	Current total harmonic distortion	MET/MHAI.ThdA.phsC.cVal.mag.f
Basic	Voltage total harmonic distortion	MET/MHAI.ThdPhV.phsA.cVal.mag.f
Basic	Voltage total harmonic distortion	MET/MHAI.ThdPhV.phsB.cVal.mag.f
Basic	Voltage total harmonic distortion	MET/MHAI.ThdPhV.phsC.cVal.mag.f

MMXN		
Fundamental	Frequency	MET/MMXN.Hz.mag.f
Fundamental	Voltage (RMS)	MET/MMXN.Vol.mag.f
Fundamental	Current (RMS)	MET/MMXN.Amp.mag.f
Fundamental	Phase active power	MET/MMXN.Watt.mag.f
Fundamental	Phase reactive power	MET/MMXN.VolAmpr.mag.f
Fundamental	Phase apparent power	MET/MMXN.VolAmp.mag.f
Others	Phase power factor	MET/MMXN.PwrFact.mag.f
MHAN		
Basic	Current total harmonic distortion	MET/MHAN.ThdAmp.mag.f
Basic	Voltage total harmonic distortion	MET/MHAN.ThdVol.mag.f
TGSN		
	Transducer (magnitude)	MET/TGSN.GenSv.instMag.f
Digital inputs		
	GOOSE inputs	DIG/GOOSEGGIO1
	Digital inputs	DIG/DIGITALGGIO1
	Digital outputs	DIG/OUTPUTGGIO1

3.2 Recording Times by Trigger

Once triggered, the following parameters are considered by the disturbance recorder:

Parameter	Allowed values (1 or 2ppc)	Allowed values (4ppc)	Increment
Pre Trigger time (t_{pre})	0 ... 2 min	0 ... 2 min	0.1 min
Post Trigger time (t_{pos})	0 ... 60 min	0 ... 30 min	0.1 min
Maximum Record time (t_{max})	1 ... 60 min	1 ... 30 min	0.1 min

The Maximum Record time configures the maximum duration that the register can reach. If consecutive retriggers or a sustained fault happens, the Maximum Record time establishes the limit of time that the COMTRADE file will register.

The maximum duration of the disturbance record is 60 minutes at 1 or 2 points per cycle or 30 minutes at 4 points per cycle.

3.3 Frequency Calculation

The DR60 calculates frequency applying a moving average filter in the derivative of the angle of the positive sequence voltage, the angle is calculated four times per cycle and so is the frequency. Except for **PMU** application, this frequency calculation methodology is used for all other DR60 functions like thresholds, disturbance recorder, web HMI and etc.

3.4 Sampling Rate

The disturbance recorder and the continuous disturbance recorder have independently configurable sampling rate that can be set to: 1, 2 or 4 samples/cycle. The binary inputs in the disturbance register are recorded with the same sampling rate as the analog channels.

3.5 Trigger Burst Limiter

There is a user-configurable trigger burst limiter for the disturbance recorder which is identical to the waveform recorder limiter Trigger Burst Limiter 1.4.

4 Trend Recorder

The trend recorder is responsible for recording minimum, maximum and average values of RMS, DC measurement and active, reactive and apparent power. The recording rate is the same as the Calculation period configured. And the duration of the record is configurable from 1 to 24 hours.

5 SOE - Sequence of Events Records

The sequence of events recorder registers the status of the binary inputs, binary output and GOOSE inputs. The recorder creates a XML file that groups the events according to COMFEDE standard (IEEE C37.239-2010 Standard for Common Format for Event Data Exchange).

The events in the SOE are recorded with accuracy better than 100µs.

The parameter "Aggregation Period" sets the duration of the records and time interval that new records are created. The aggregation period can be configured from 1 – 1440 min.

5.1 Sampling Rate

The SOE sampling rate is the same sampling rate configured in the Waveform Recorder: 256 or 512 samples/cycle. In case the Waveform is not enabled in the configuration the SOE recorder will use 256 samples/cycle as sampling rate.

6 Record Format and Naming, and Mass Storage Capacity

6.1 Record Format

Records are created in accordance with the COMTRADE standard IEEE C37.111-2013, *IEEE Standard Common Format for Transient Data Exchange for Power Systems*. The COMTRADE records in the DR60 are comprised by the “.cfg” and “.dat” files described in the standard.

6.2 Record Naming

Records are named using the COMNAME methodology, according to IEEE C37.232-2011, *Common Format for Naming Time Sequence Data Files (COMNAME)*.

Fault, Disturbance, Steady-state, and Sequence of Events records are named as follows:

`STARTDATE,STARTTIME,TIMECODE,STATIONID,DEVICEID,COMPANY.CFG`
`STARTDATE,STARTTIME,TIMECODE,STATIONID,DEVICEID,COMPANY.DAT`

The table below describe each parameter in the file name.

Parameter	Format	Description
STARTDATE	yymmdd	Record's start date (year, month, day)
STARTTIME	hhmmssuuuuuu	Record's start time (hour, minutes, seconds, microseconds)
TIMECODE	soohmm	Indication of timezone offset (the last three characters are included only when fractional hours are in use)
STATIONID		Location of the equipment, configurable in: GENERAL > LOCATION (up to 255 characters)

DEVICEID		Equipment identifier, configurable in: GENERAL > IDENTIFIER (up to 61 characters)
COMPANY		Equipment owner description, configurable in: GENERAL > OWNER (up to 255 characters)

6.3 Mass Storage Capacity

Record type	Internal Path	SSD Capacity
Fault	/data/fault	19,1 GB
Disturbance	/data/disturbance	7,7 GB
SOE	/data/soe	1 GB
Trend	/data/steadystate	1 GB

The device will automatically remove the oldest records as the soon as mass storage occupation exceeds 90%.

All DR60 files including configuration and records are stored in the SSD non-volatile memory.

7 Record Management and Access

To retrieve the COMTRADE files from the DR60, user can use either a SFTP client or the DR Manager tool.

The DR60 is equipped with a SFTP server, any tool compliant to communicate via SFTP protocol can connect to the DR60 to download records.

To do so, using the SFTP client, access the DR60 address at port 22 and use the access credentials. Below are the default users and passwords:

User	Password
adm	RX8jg3S&mDx
cfg	UV@bM8DtqAN
mon	QcURcm"Gk3P

To download records using the DR Manager, open the DR Manager tool and follow the instructions below.

7.1 Creating Installations

Within the Reason DR Manager software, the process to create a new Installation is:

1. Click <SETTINGS> menu and then click <INSTALLATIONS>;
2. Click <NEW> to create. Type the Installation's name and description and then press <OK>.

The user can view the list of registered substations and add, edit, or remove a substation. Substations can only be removed without any equipment being associated.

7.2 Creating Devices

The user can view the list of registered equipment, add, edit, or remove some equipment. Equipment can only be removed if the Auto Polling is disabled.

The process to create a new device is:

- Click <SETTINGS> menu and then click <DEVICES>;
- Click <NEW> to create.;
- At <HOST>, type equipment's IP address;
- Choose the model of the device: RPV or DR60;
- Choose device installation in the Installation list;
- Add the username and password for the device;
- Click at <Get Info> and then press <Ok>;

The figure below shows the Device configuration window.

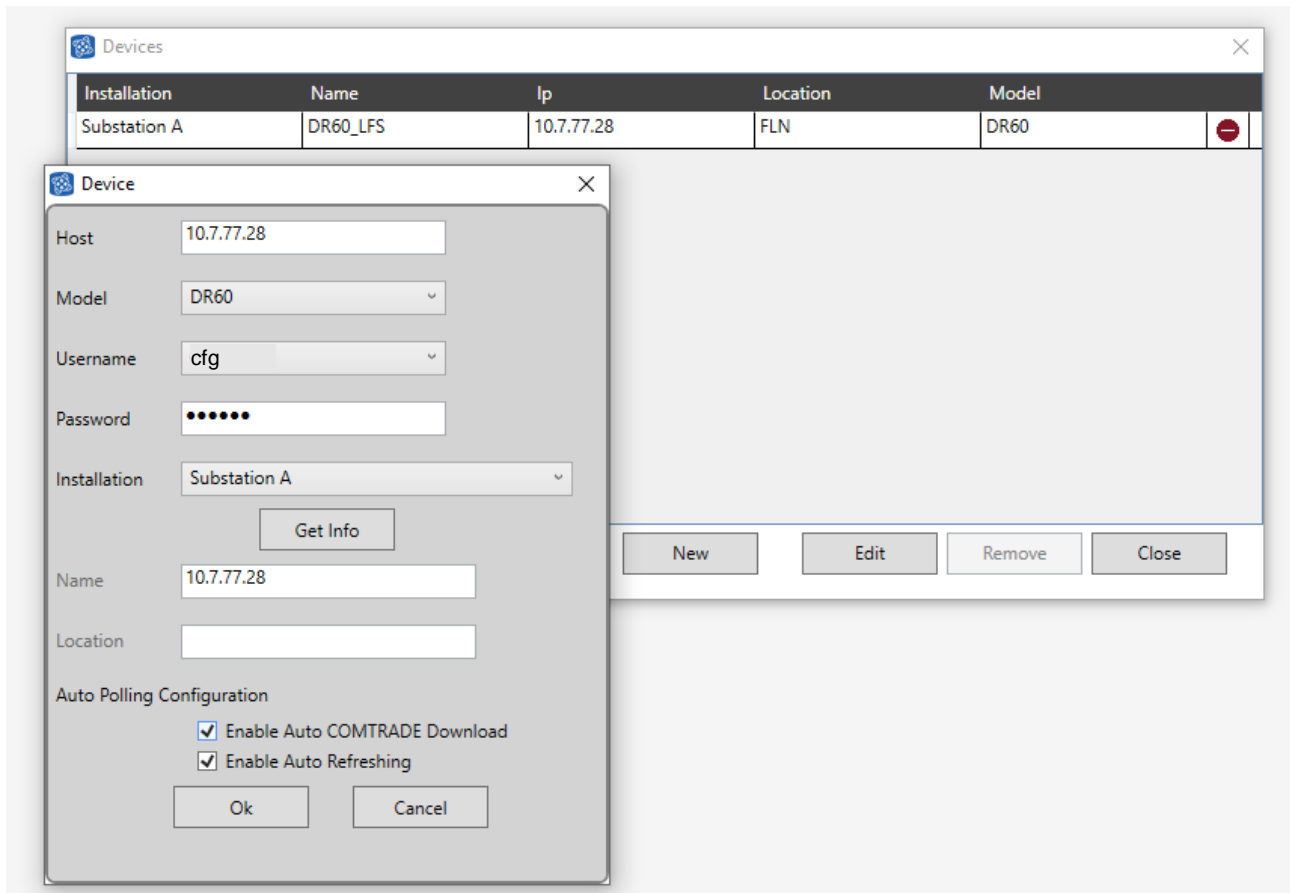

There are two parameters to be configured by the user:

Enable Auto COMTRADE Download: When enabled, the unit will be part of the Auto Polling process, where records not yet saved are automatically downloaded.

Enable Auto Refreshing: When enabled, the unit will be part of the process of Auto Refresh, where the equipment state will be updated automatically during the process. The user can change the equipment host address and enable or disable the "Enable Auto COMTRADE Download" and "Enable Auto Refreshing". At the end of the editing, the software automatically communicates with the equipment in order to upgrade the name and location information.

If the equipment is associated with any transmission, a message will be shown to the user at the beginning of the Edit.

Note: To confirm compatibility in between DR60 and Reason DR Manager, please check the release notes for the versions you are using.

DR60 firmware version 02A04.1 and above shall be compatible to Reason DR Manager version 9.2.6 and above.

Note: Further and detailed information on the DR Manager configuration and use can be found in its technical manual DR_Manager_TM. Download on GE Grid website.

*Note: For DR60 and Reason DR Manager integration the allowed users are **cfg** or **adm**.*

DR60

Digital Recorder

Chapter 6: Impedance Fault Location

This chapter provides detailed information about Impedance Fault Location feature.

1 Impedance Fault Location Introduction

DR60 provides methods and algorithms to perform single ended impedance fault location with a typical accuracy of $\pm 2\%$ of the line length for solid faults.

The algorithm runs in real time embedded in the device for each circuit, single phase (MMXN) or three phase (MMXU) configured to enable this feature, allowing it to be send to SCADA systems or other equipment.

The fault location is treated according to the IEC 61850 logical node for fault location: **RFLO**. The calculated location can be sent through MMS, Report Control Block or DNP3 by selecting the data attribute *RFLOxFItDiskm.mag.f* within the MX functional constraint. This information can be seen in DR60 web interface along with other user logs, as show the image below.

LOG MESSAGES

Download Show/Hide Column ▾

Id	Timestamp	Code	Description
Filter	Filter	Filter	Filter
4980	11/29/2019 18:33:24.262	LL02	Threshold RADR2 violated
4981	11/29/2019 18:33:24.262	LL02	Threshold RADR3 violated
4982	11/29/2019 18:33:24.277	LA03	No signal applied on analog channel TVTR33
4983	11/29/2019 18:33:24.385	LF01	Fault Locator RFLO1: type Fault AG, distance 60.26
4984	11/29/2019 18:33:24.521	LR02	New record available, type: Waveform

2 Advanced Configuration

This function can be enabled through the advanced settings of each circuit as mentioned in Chapter 4, section 5.2.1.

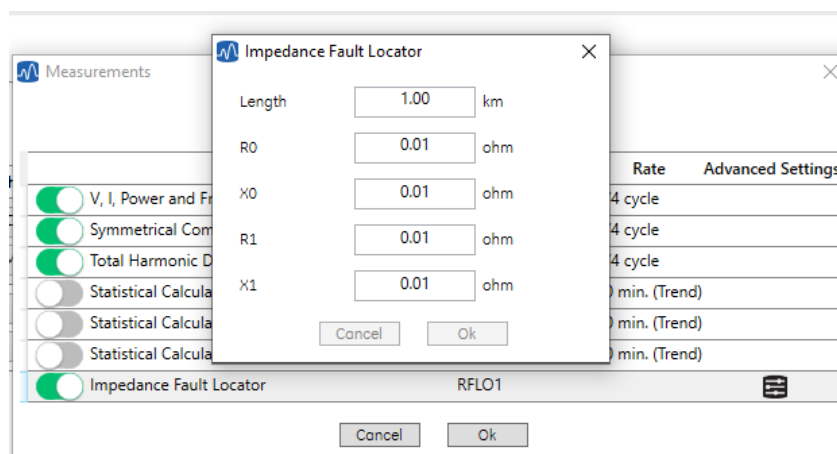

The Impedance Fault Location parameters configuration panel is accessible through the button advanced settings (⚙️), allowing the user to configure:

- Length: Line length where the fault is to be calculated.
- R0: Total zero sequence resistance in ohms considering the full line length.
- X0: Total zero sequence reactance in ohms considering the full line length.
- R1: Total positive sequence resistance in ohms considering the full line length.
- X1: Total positive sequence reactance in ohms considering the full line length.

The fault location algorithm is triggered for all analog thresholds configured for the circuit which the RFLO is enabled and it will be clear for the user on the triggering matrix as illustrate the image below.

		Recorders		Fault Locator
		Waveform	Disturbance	RFLO
^ Thresholds F > 61.00 Hz F < 58.00 Hz	MMXU1			[X]
	MMXN2			[X]
v Binary Inputs				

Binary thresholds and equations will not trigger the impedance fault location algorithm.

2.1 Communication – DNP3

To send the calculated fault location through DNP3 follow the steps:

1. Enable the **RFLO** for the circuits you want to monitor, according to section 5.2.1;
2. Navigate to the tab **Communication**, subtab **DNP3** and enable it;
3. Under the section **Input Selection** click in <ANALOG>;
4. Use the IEC61850 naming to Find the fault locations you want to send selecting the data attribute *RFLOxFItDiskm.mag.f*;
5. Add it to your DNP3 mapping by pressing the add button
6. Click <Ok> to finish the process.

Analog

Filter

RFLO

Attribute Address
DR60FLO/RFLO1.FitZ.cVal.mag.fjMX
DR60FLO/RFLO2.FitZ.cVal.mag.fjMX

>>
<<

Attribute Address	Class1	Class2	Class3	Scale	Deadband
DR60FLO/RFLO1.FitDiskm.mag.fjMX	<input type="checkbox"/>	<input type="checkbox"/>	<input type="checkbox"/>	1.000	0
DR60FLO/RFLO2.FitDiskm.mag.fjMX	<input checked="" type="checkbox"/>	<input checked="" type="checkbox"/>	<input checked="" type="checkbox"/>	1.000	0

Cancel Ok

DR60

Digital Recorder

Chapter 7: PMU

This chapter provides detailed information about the PMU feature.

1 Synchrophasor Measurement and Broadcast

The DR60 provides powerful and cost-effective synchrophasor measurement solution according to IEEE C37.118.1/2-2011/1a-2014 standards and is capable of transmitting synchrophasors in up to 4 separate data streams. Each stream can be configurable independently based on: contents; frame rate; performance class (P or M) and communication mode (TCP or UDP).

1.1 Reported Values

Reported values	
Phasors	Voltage synchrophasors (any phase)
	Current synchrophasors (any phase)
	Positive, Negative and Zero sequence for voltage circuits
	Positive, Negative and Zero sequence for current circuits
Frequency	Frequency and frequency variation of one circuit

Note:

Although DR60 datasets can be configured with several type of data as transduced measures, circuit calculated measures and digital I/Os, through the **IEEE C37.118.2-2011** protocol only synchrophasors, sequences, frequency and ROCOF are reported.

1.2 Accuracy Limits

The Total Vector Error is defined through

$$\text{TVE} = \sqrt{\frac{(X_r(n) - X_r)^2 + (X_i(n) - X_i)^2}{X_r^2 + X_i^2}}$$

Represents the magnitude of the error vector, obtained by subtracting the measured synchrophasor of the theoretical value. It is represented as a fraction of the magnitude of the theoretical value.

In the equation above, $X_r(n)$ and $X_i(n)$ are the measured values, while X_r and X_i are the theoretical values of the input signal at the instant of measurement.

All 1A and 5A analog inputs/boards have the proper accuracy necessary for the PMU solution to be rated as level 1 compliant according to IEEE C37.118 under the condition below.

Influence quantity	Range	TVE max
Signal frequency	± 5 Hz of f_{nom}	1 %
Signal magnitude	10 % ... 120 % rated	1 %
Phase angle	± 180°	1 %
Harmonic distortion	10 % ¹	1 %
Out-of-band interfering signal ³ $ f_i - f_N > \frac{F_s}{2}$	10 % ²	1 %

¹ Any harmonic up to 50th order

² Of input signal magnitude

³ f_i frequency of interfering signal, f_N nominal frequency and F_s synchrophasors broadcast frequency

1.3 Communication Ports, Transmission Rates

The PMU streams have their source port configurable from the port 4712 to 4732. Always configure different streams at different ports. Only 1 stream can work at once per port.

The DR60 allows the following transmission rates: 60 frames/second at 60 Hz and 50 frames/second at 50Hz.

1.4 Configuration

To quickly configure the DR60 to transmit PMU, follow the steps below:

- 1) Go to the *Analog* configuration tab and add a new circuit. Configure the physical inputs and transformer ratios.

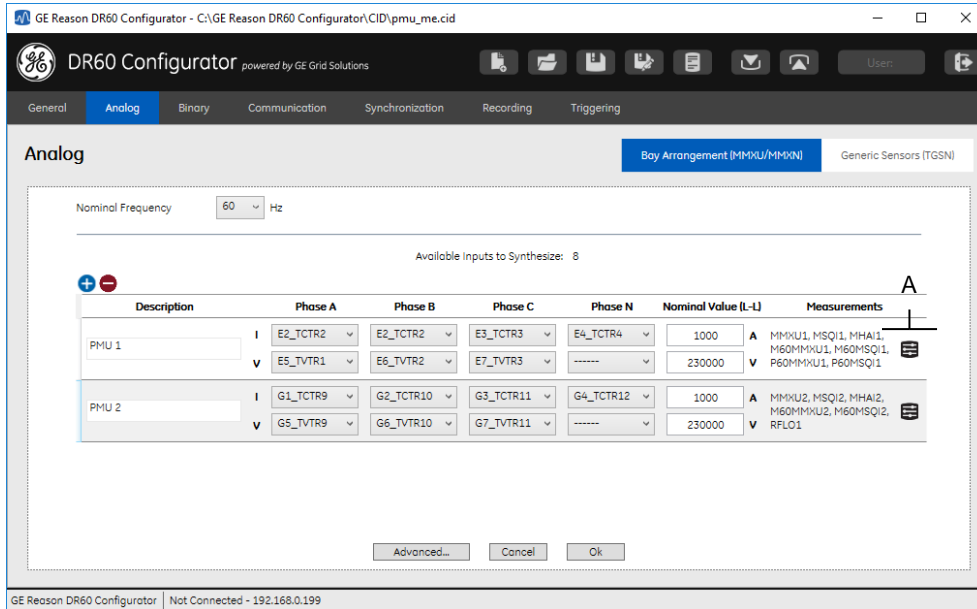

- 2) Click  (A in the figure above), the screen below will show up. Activate the PMU Class and select the fps configuration. Every PMU is mapped in separate IEC 61850 logical node. For more detail on these configuration screens, refer to Chapter 4 – Configuration; 5.2.1 Bay Arrangement (MMXU/MMXN)

GE Reason DR60 Configurator

DR60 Configurator powered by GE Grid Solutions

General Analog Binary Communication Synchronization Recording Triggering

Bay Arrangement (MMXU/MMXN)

Measurements

Enabled PMUs Number: 4

Circuit1

Logical Node	Rate	Advanced Settings
<input checked="" type="checkbox"/> V, I, Power		
<input checked="" type="checkbox"/> Symmetric		
<input checked="" type="checkbox"/> Total Harm		
<input type="checkbox"/> Statistical C		
<input type="checkbox"/> Statistical C		
<input type="checkbox"/> Statistical Calculation - Average	AVGMMXU1	10 min. (Trend)
<input checked="" type="checkbox"/> M-Class Phasor Measurement Unit	M60MMXU1	60 fps
<input checked="" type="checkbox"/> P-Class Phasor Measurement Unit	P60MMXU1	60 fps
<input type="checkbox"/> Impedance Fault Locator	RFLO1	

Frequency and ROCOF Reference: M60MSQ11.SeqV.c1

Value (L-L) Measurements

Value (L-L)	Measurements
A	MMXU1, MSQ11, MHAI1, M60MMXU1, M60MSQ11, P60MMXU1, P60MSQ11
V	
A	MMXU2, MSQ12, MHAI2, M60MMXU2, M60MSQ12, P60MMXU2, P60MSQ12
V	

GE Reason DR60 Configurator | Not Connected - 192.168.0.199

- 3) Click in the advanced settings button  associated to each PMU to configure what will be reference for frequency and ROCOF of that PMU. It is possible to choose in between the circuit phases or sequencies.
- 4) A new dataset containing the PMU synchrophasor, frequency and rate of change of frequency will be created automatically for each PMU circuit and class. The datasets can be access on the *Dataset* configuration tab shown in the figure below. For more details on the Dataset configuration tab, refer to Chapter 4 – Configuration; 5.4.2 Datasets

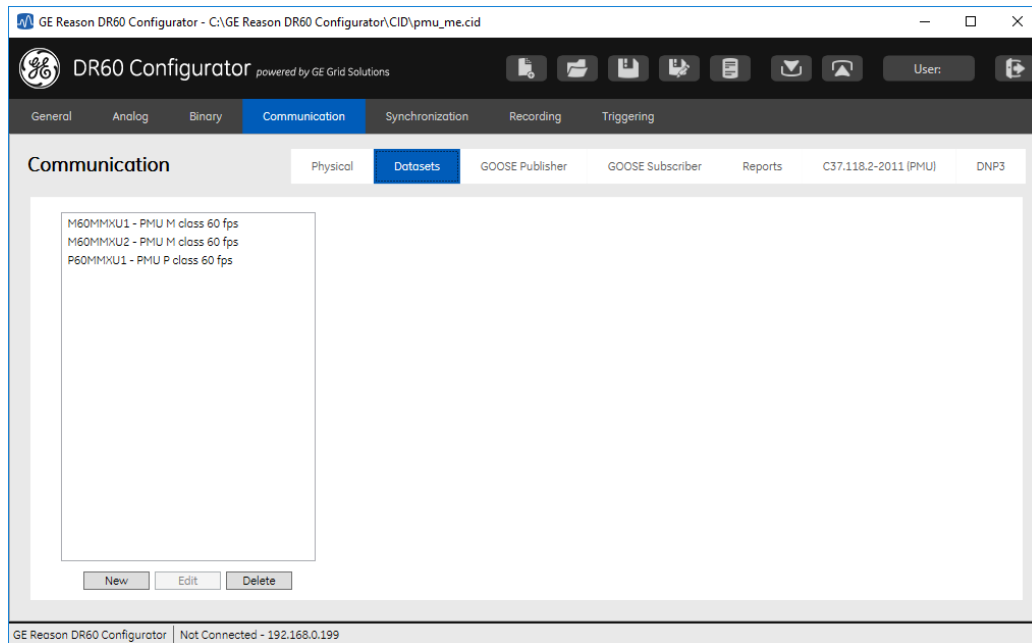

- 5) Access *Communication*> *C37.118.2-2018 (PMU)* configuration tab to configure the communication parameters related to the PMU streams, figure below. Chapter 4 – Configuration; 5.4.6 C37.118.2-2011 (PMU)

1.5 Transmission Protocol

The synchrophasor data frames are transmitted from the PMU over Ethernet using TCP/IP or UDP/IP.

TCP (Transmission Control Protocol) is a connection-oriented protocol. It manages message acknowledgement, retransmission and timeout. TCP is reliable and ordered, but high on overheads.

UDP (User Datagram Protocol) is a simpler protocol that transmits messages irrespective of the state of the receiving device. It does not care whether the frames arrive at their destination or not, and it will not retransmit lost frames. UDP is unreliable and disordered, but low on overheads.

The choice of protocol will come down to the specific requirements of the application. UDP is usually used for streamed real-time data, where the loss of a few pieces of information is not critical, but where real-time transmission is necessary (for example, live television pictures). TCP is usually used where the integrity of the sent data must be guaranteed (for example a file transfer).

1.6 Communication Mode

1.6.1 Spontaneous

Spontaneous UDP may be required for several reasons, e.g. for security purposes, where a firewall has been set up to block incoming data.

With spontaneous UDP, the PMU will continually transmit the phasor data, interspersed with configuration data. This is configured such that it transmits a batch of phasor data followed by a few frames of configuration data continuously. The configuration frames are in the format CFG-2 and CFG-3 according to the described by IEEE C37.118.2-2011.

The configuration or header frames will be sent every minute in addition to the regular transmission of the phasor data.

Two types of spontaneous destination are available: unicast and multicast.

The sending device needs to know where to send the data. So, the user needs to define the destination UDP port number and IP address (unicast or multicast) in the **Destination Address** field.

1.6.2 Commanded

The Commanded mode supports two types of transmission protocols: UDP and TCP.

In this mode, the PMU can accept commands from outside, therefore the receiving device can initiate and control the flow of communication. The commanded PMU will only start transmitting synchrophasors after receiving an external command to do so. The destination address is the same as the address sending the command.

1.7 Ethernet interfaces and PMU Routes

DR60 has two non-redundant ethernet interfaces and PMU streams are routable for either interfaces depending on the configuration:

- If the stream is configured to be commanded, it means that both interfaces will answer depending on which the client command get to the stream.
- If the stream is configured to be spontaneous unicast, the source ethernet interface will depend on the **Destination Address** and the routes in the equipment:
 - If the configured **Destination Address** is in the same local network that one of the interfaces, that is the one from where the stream will be communicated;
 - Otherwise, the stream will be communicated through the primary gateway on ethernet 1.
- If the stream is configured to be spontaneous multicast, the source ethernet interface will depend on the configured **Output Interface**.

- For all the cases, note that the same flux shall never be available in two ethernet interfaces at the same time.

1.8 PMU Standards Compliance

The DR60 PMU Class M and P complies with the following standards:

IEEE C37.118-2005
IEEE C37.118.1-2011
IEEE C37.118.2-2011
IEEE C37.118.1a-2014

1.9 PMU Specification

PMU Specification	
Number of simultaneous PMU streams	4
Performance Class	P and M
Communication Protocol C37.118.2	UDP or TCP
Communication mode	Commanded and spontaneous
PMU data	Voltage and current synchrophasors; frequency, rate of change of frequency and sequence components
Ethernet interfaces	2 RJ45 or 2 LC connector
VT inputs	115 V nominal; up to 16 inputs
CT inputs	1 or 5 A nominal; up to 16 inputs
Transducer inputs	Not supported
Digital I/O	Not supported

DR60

Digital Recorder

Chapter 8: Communications

This chapter provides detailed information about the communication options and how to configure them.

1 Communication Interfaces – Slot B

The DR60 has two Ethernet interfaces that can be either electrical or optical and two serial interfaces with DB9 female connectors, serial A and B are RS232.

1.1 Electrical and Optical Ethernet

The DR60 has 2 non-redundant Ethernet interfaces named Ethernet 1 and Ethernet 2. The table below describes the usage of each port:

Port	Usage
Ethernet 1	Configuration, monitoring, GOOSE publishing / subscription, MMS report control block publication, DNP3, PMU, firmware upgrade, log and registers download.
Ethernet 2	Configuration, monitoring, PMU, firmware upgrade, log and registers download.

Both interfaces can be either optical with LC connectors or electrical with RJ45 connectors.

The figure below shown the pinout diagram.

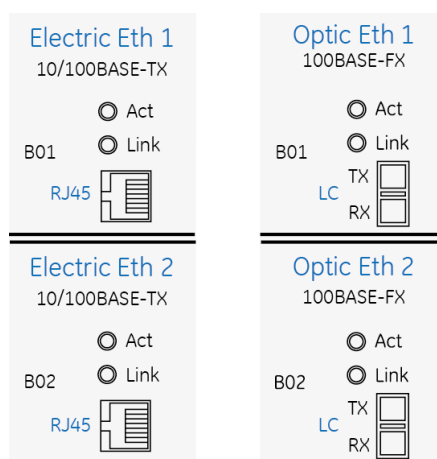

Electrical and optical Ethernet inputs

To minimize EMC effects, the use of fiber-optic cables is recommended for applications where the length of the cable is greater than 3 m or connection between panels.

**Note:**

Applying signals to the Ethernet ports at 50 MHz frequency may cause mal functioning of the ports.

1.1.1 Ethernet Port Default Settings

The Ethernet interface default settings are:

Parameter	Default Setting	
	Ethernet port 1	Ethernet port 2
IP Address	192.168.0.199	192.168.1.199
Network mask	255.255.255.0	255.255.255.0
Gateway	192.168.0.254	192.168.1.254

1.2 Serial Port

The DR60 has 2 serial ports with DB9 female connectors. The serial ports can be used for configuration download/upload, firmware upgrade and logs download.

The Serial A and Serial B are RS232 type. The pinout of the serial ports is shown in the figure below.

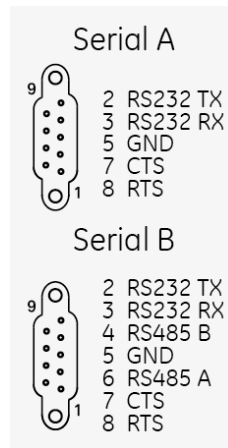

Serial communication port

Note: RS485 mentioned in Serial B is not functional in this DR60 version

2 Communication Ports and Protocols

The DR60 web interface was designed using the GE Predix UI platform and it can be accessed using Mozilla Firefox or Google Chrome browser from computers, cellphones or tablet.

The web interface uses the following ports and protocols. These ports must be properly configured in the routers and firewalls for the communication work completely.

Port	Protocol	Use
22	SFTP	Download COMTRADE files
22	SSH	Configuration download and upload, logs download and firmware upgrade
443	HTTPS	Web monitoring interface
102	MMS	MMS Report control block
4220	UDP/IP	IP recovery tool Ethernet 1
4221	UDP/IP	IP recovery tool Ethernet 2
502	TCP	MODBUS interface
20000	DNP3	DNP3 transmission

4712-4732	PMU	C37.118.2-2011 PMU transmission
-----------	-----	---------------------------------

3 Recovering the DR60 IP Address

To verify the recovering of the DR60 IP address or to validate the communication between the device and the computer, the DR60 has a scanning tool in the DR60 Configurator tool which scans the network returning the IP Address of the found DR60.

The scanning tool is located in the Communication menu and is described in the Configuration Chapter.

4 Accessing the Equipment

The DR60 has basically two means of access. The window tool named DR60 Configurator is used to configure, download logs and firmware upgrade; and the Web Interface for monitoring and remote trigger. Detailed information on how to proceed the access using both ways is described in the Configuration Chapter.

The minimum requirements for the web interface are described in the next section and the for the DR60 Configuration tool in the Installation Chapter.

4.1 Web Interface Minimum Requirements

Web interface requirement: Internet Explorer version 7 or higher, or Mozilla Firefox version 3.0 or higher;

DR60

Digital Recorder

Chapter 9: Installation

This chapter provides information about the product installation.

1 Handling the Goods

Our products are of robust construction but require careful treatment before installation on site. This section discusses the requirements for receiving and unpacking the goods, as well as associated considerations regarding product care and personal safety.



Before lifting or moving the equipment you should be familiar with the Safety Information chapter of this manual.

1.1 Receipt of the Goods

On receipt, ensure the correct product has been delivered. Unpack the product immediately to ensure there has been no external damage in transit. If the product has been damaged, make a claim to the transport contractor and notify us promptly. For products not intended for immediate installation, repack them in their original delivery packaging.

1.2 Unpacking the Goods

When unpacking and installing the product, take care not to damage any of the parts and make sure that additional components are not accidentally left in the packing or lost. Do not discard any technical documentation. These should accompany the unit to its destination substation and put in a dedicated place.

The site should be well lit to aid inspection, clean, dry and reasonably free from dust and excessive vibration. This particularly applies where installation is being carried out at the same time as construction work.

1.3 Storing the Goods

If the unit is not installed immediately, store it in a place free from dust and moisture in its original packaging. Keep any de-humidifier bags included in the packing. The de-humidifier crystals lose their efficiency if the bag is exposed to ambient conditions. Restore the crystals before replacing it in the carton. Ideally regeneration should be

carried out in a ventilating, circulating oven at about 115°C. Bags should be placed on flat racks and spaced to allow circulation around them. The time taken for regeneration will depend on the size of the bag. If a ventilating, circulating oven is not available, when using an ordinary oven, open the door on a regular basis to let out the steam given off by the regenerating silica gel.

On subsequent unpacking, make sure that any dust on the carton does not fall inside. Avoid storing in locations of high humidity. In locations of high humidity, the packaging may become impregnated with moisture and the de-humidifier crystals will lose their efficiency.

The device can be stored between –25° to +70°C for unlimited periods or between -40°C to + 85°C for up to 96 hours (see technical specifications).

1.4 Dismantling the Goods

If you need to dismantle the device, always observe standard ESD (Electrostatic Discharge) precautions. The minimum precautions to be followed are as follows:

Use an antistatic wrist band earthed to a suitable earthing point.

Avoid touching the electronic components and PCBs.

2 Normal Use of the Equipment

To maintain the equipment integrity, levels of protection and assure user safety, the device shall be installed in an enclosed panel with recommended ingress protection rating of IP42 or above. The DR60 shall be kept in an environment where it is protected against impact and water. The enclosing panel shall ensure that the equipment rear connections are not exposed, meanwhile maintaining adequate temperature and humidity condition for the devices. Furthermore, the equipment shall have all their rear connectors attached, even if not being used, in order to keep their levels of ingress protection as high as possible.

The DR60 is IEC 60255-27:2014 Overvoltage Category III and Pollution Degree II (using the 100-250 Vdc / 110-240 Vac power supply); or Overvoltage Category II and Pollution Degree II (using the 24-48 Vdc power supply). These ratings allow mounting of the equipment indoors or in an outdoor (extended) enclosure where the equipment is protected against exposure to direct sunlight, precipitation, and full wind pressure.

During the normal use of the device only its frontal panel shall be accessible.

3 Mounting the Device

3.1 DR60 Mechanical Installation

The screws used for fixation are of the M6 type.

It is possible to order an optional support for installation of one or two units adapted to a 19-inch rack. To install either a single or two modules of the DR60 use the optional supports shown in the Installation Chapter - Accessories

For information about the equipment dimensions, refer to the Technical Specifications Chapter.

The equipment is designed for outdoor installation in proper panel. The panel must be designed for the environmental conditions to which it is subject.

The DR60 should always be sheltered from the weather. For indoor use, the equipment must be installed inside panel with IP41 (IEC) enclosure protection or minimal type 3 (NEMA). For outdoor use, the equipment must be installed inside panel with IP55 (IEC) enclosure protection or type 3, 3X, 3S or 3SX (NEMA), according to the local environmental conditions, complying the IEC 60529 and NEMA 250-2003 standards requirement.

The panels should be submitted to insulation test according to IEC 60255-5 standard (minimum insulation resistance of 10 MΩ and be submitted to test of dielectric voltage insulation of 2kV AC)

An additional panel designed for the DR60 application environment may be provided upon request. For more information on panel options, please contact GE Contact Center.



It is recommended that 1 rack unit of space (1.75") be kept unpopulated and free of equipment above each DR60 to allow for a small amount of convectional airflow. Although forced airflow is not necessary, any increase in airflow will result in a reduction of ambient temperature that will improve long-term reliability of all equipment mounted within the rack space.

4 Cables and Connectors

This section describes the type of wiring and connections that should be used when installing the device, as well as pin-out details.



Before carrying out any work on the equipment you should be familiar with the Safety Section and the ratings on the equipment's rating label.

In order to meet the EMC CISPR22 emission levels, the power supply, CT, VT and binary signals connection shall use screened (shielded) cables with screen coverage of 70%; Core wires should be as short as possible; The shield should be connected to any of the two functional earth terminal screws positioned on the upper and lower-middle parts of the

frontal panel of the equipment through short pigtails. Recommended lug terminal to the pigtail end connection.

4.1 Power Supply Connections

The unit can be powered from DC or AC power within the limits specified in the Technical Specifications Chapter.

All power connections should use insulated flameproof screened/shielded cable with a 2.5 mm² cross section, 70° C (158 °F) thermal class, and 750 V insulation voltages.

To reduce the risk of electrical shock, pre-insulated tubular pin terminals should be used on the ends of the power connections.

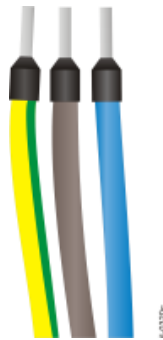

Pre-insulated tubular pin terminals

The pin terminals should be completely inserted into the connector supplied with the unit so that no metallic parts are exposed, according to the picture below.

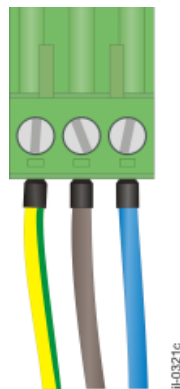

Supplied connector assembly

A 1.5 mm² ground straps shall be connected to the terminal marked with the protective earth symbol for safety.

For optimal electromagnetic compatibility, ground the unit by using a screened/shielded cable with insulated flexible wires of 4.0 mm² cross section connected to the rear panel of the device using the protective earth screw.

4.1.1 AC and DC Power Connection

Figure below shows the wiring diagram for the AC and DC power connection. Phase or positive should be applied to terminal A05, neutral or negative to terminal A06, and ground to terminal A04.

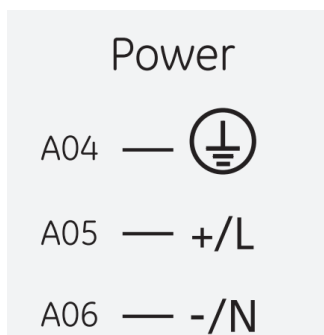

AC and DC power connection

For safety purposes, install a suitable external switch or circuit breaker in each current-carrying conductor of DR60 power supply; this device should interrupt both the hot (+/L) and neutral (-/N) power leads. An external 10 A, category C, bipolar circuit-breaker is recommended. The circuit breaker should have an interruption capacity of at least 25 kA and comply with IEC 60947-2. The switch or circuit-breaker must be suitably located and easily reachable, also it shall not interrupt the protective earth conductor.

For information about the nominal operating voltage range or maximum voltage applicable, power and frequency, refer to Technical Specifications Chapter.

4.2 Powering Up

1. Before energizing the unit, be familiar with all the risk and attention indicators in the equipment's frame.
2. Connect the power supply (including the ground strap) to the appropriate terminals. The equipment will start the boot process.
3. The equipment performs a self-test procedure. At the end of the self-test, if it is operating and has already been configured, the IN SERVICE indicator lights up on the front panel of the equipment and the signaling contact IN SERVICE on the rear panel of the equipment will be on.
4. If is the first time using the equipment, it is necessary to configure it. Before the configuration, equipment will performance accordingly with the application.
5. To turn off the unit, disconnect the power supply (including the ground strap) from the terminals. All front and rear panel indicators will turn off.

In case the unit does not behave in a way here described or if the ALARM indicator lights up, turn off the equipment and carefully check all power and signal connections. Repeat the procedure described and if the problem persists, please contact GE Contact Center. For additional suggestions for problem diagnosis, refer to Maintenance Chapter.



Note:

The equipment will not come into operation mode and will not light up the IN SERVICE indicator before the first configuration

4.3 Earth Connection

To ensure proper operation of the equipment under adverse conditions of electromagnetic compatibility, connect the equipment protective earth terminal to the panel using a screened/shielded cable with insulated flexible wires of 4.0 mm² cross section. As shown in the figure below.

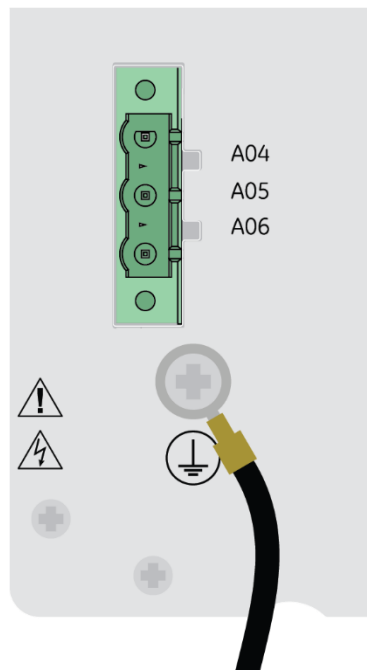

DR60 Earthing

Additionally, to meet the EMC CISPR22 emission levels, two other functional earth terminals are available on upper-middle and lower middle parts of the frontal panel (see Installation Chapter Section 3.1 DR60 Frontal Panel) of the equipment marked with the sing below:

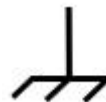

Power supply, CT, VT and binary signals shall use screened/shielded cable. Connect the shield of the cable to both functional earth terminals using short pigtailed with lug terminals.

4.4 IN SERVICE Contact

The DR60 has a contact for signaling equipment failure (failsafe), located in Slot A, shown in figure below. The IN SERVICE contact is normally closed (NC) and it opens when the equipment goes into normal operation. In case of firmware or hardware failure or shutdown of the equipment, the contact will close.

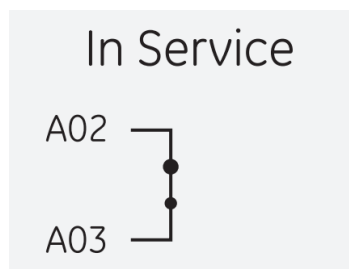

IN SERVICE contact for signaling equipment failure

For information about the IN SERVICE contact specifications, refer to the Specifications Chapter.

Connections shall use insulated flexible wires of 1.0 mm² cross section, voltage rating of 300Vrms.

Apart from the turning off, the events on the alarm table below will activate the IN SERVICE contact:

Alarms	Description
Card not detected	Happens when any board according to the device CORTEC is not detected
Card not compatible	Happens when any board is not in accordance with the device CORTEC
Invalid card	Happens when any board is not recognized by the device
Record memory full	Happens when the memory becomes 98% full
Loss of ethernet link 1	Loss of communication with ethernet interface 1
Internal temperature	Internal temperature exceeded 80°C
Internal voltage	Internal voltage automonitoring alarm
Record memory > 98%	Records memory exceeds 98%

4.5 Optical IRIG-B Input

Time synchronization is provided by temporal signal format IRIG-B004. The IRIG-B ensures that the frequency of data acquisition stays constant and maintaining the internal clock synchronized.

The DR60 has an optical IRIG-B input located in Slot B as shown in figure below

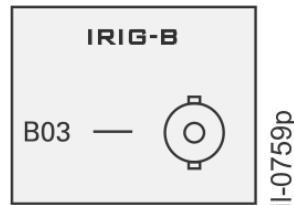

Optical IRIG-B input

The equipment signals SYNC on the front panel when the data acquisition frequency is in accordance with the equipment's nominal acquisition frequency and the equipment's internal clock is updated.

To synchronize the equipment using fiber-optic input, use the appropriate fiber-optic type, considering its minimum curvature radius. For information about the optical input specifications, refer to the Technical Specification chapter

4.6 Serial ports

The DR60 has 2 serial ports with DB9 female connectors. The serial ports can be used for configuration download/upload, firmware upgrade and logs download.

The Serial A and Serial B are RS232 type. The pinout of the serial ports is shown in the figure below.

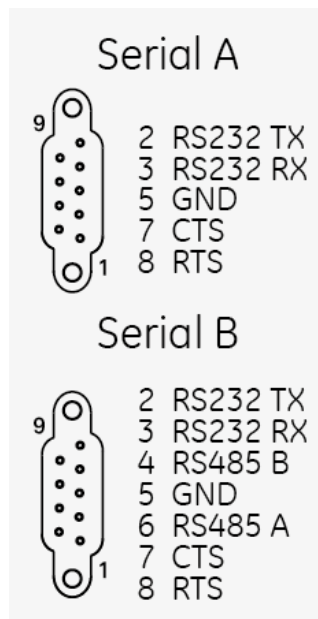

Note: RS485 mentioned in Serial B is not functional in this DR60 version

Note: To avoid electromagnetic interference and safety issues always use an extra isolation on RS232 interfaces if using DNP3 communication. This extra isolation can be an electrical-optical communication converter.

4.7 I/O Nomenclature

The binary inputs in the DR60 Configurator are identified sequentially as Ind1, Ind2 up to Ind96. Each slot from Slot C to H reserves 16 channels for either binary inputs or binary outputs (BO).

The current inputs are identified as TCTR and the voltage inputs as TVTR (IEC 61850 naming for analog channels for current and voltage respectively).

Below is a list with the designation of each input depending on its installation slot.

Slot C: Ind1...Ind16; BO 01...BO 08 (the first BI will be the Ind1)

Slot D: Ind17...Ind32; BO 17...BO 32

Slot E: Ind33...Ind48; BO 33...BO 48; TCTR1...TCTR4; TVTR1...TVTR4

Slot F: Ind49...Ind64; BO 49...BO 64; TCTR5...TCTR8; TVTR5...TVTR8

Slot G: Ind65...Ind80; BO 65...BO 80; TCTR9...TCTR12; TVTR9...TVTR12

Slot H: Ind81...Ind96; BO 81...BO 96; TCTR13...TCTR16; TVTR13...TVTR16

Below is an example of the naming of the DR60 I/O according to the definitions mentioned aforementioned.

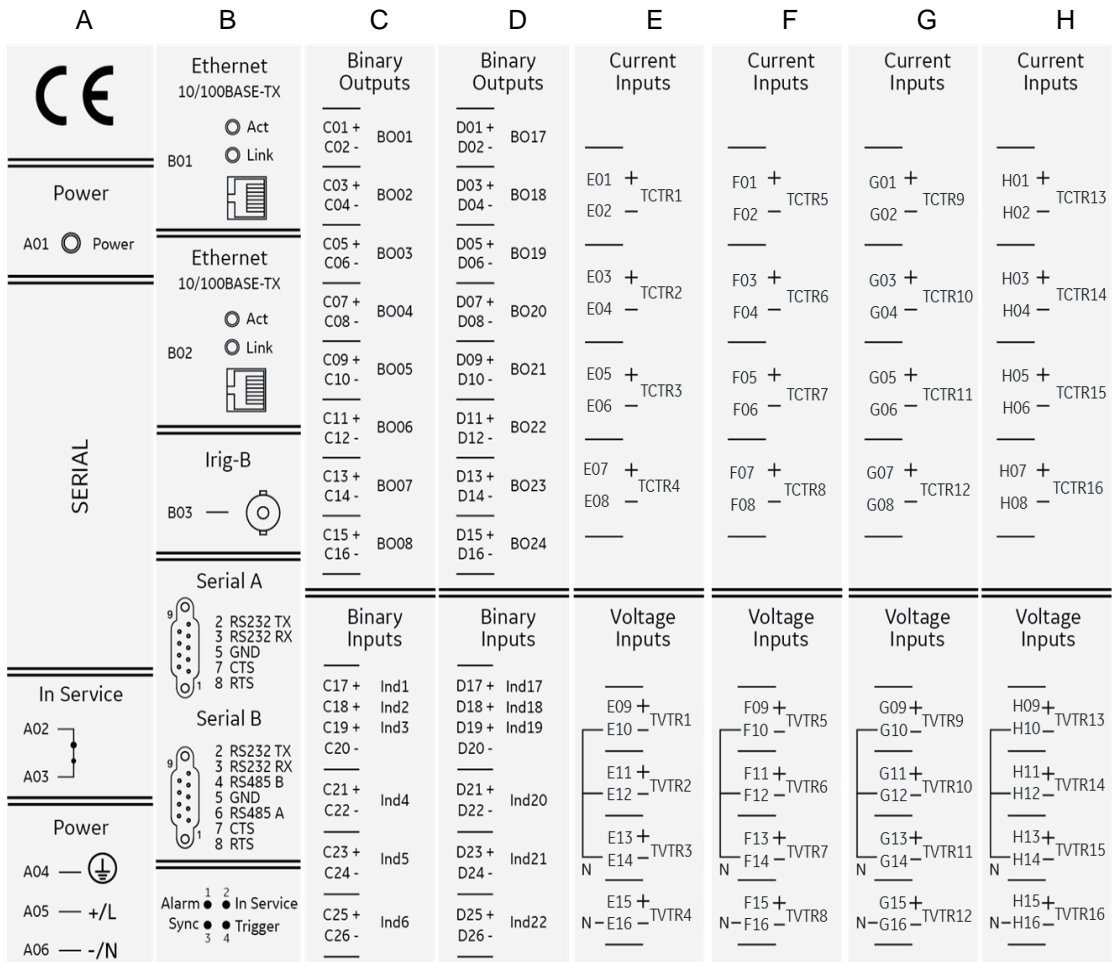

Example of the binary and analog channels name tags

4.8 Binary Inputs and Outputs/

The binary inputs and outputs are supported in slots C to H of the DR60. There are two different types of boards for the binary slots C and D. The model *B1* has 16 Binary Inputs and model *B2* has 8 Binary Outputs and 6 Binary Inputs. It is possible to use either board in any slots from C to H.

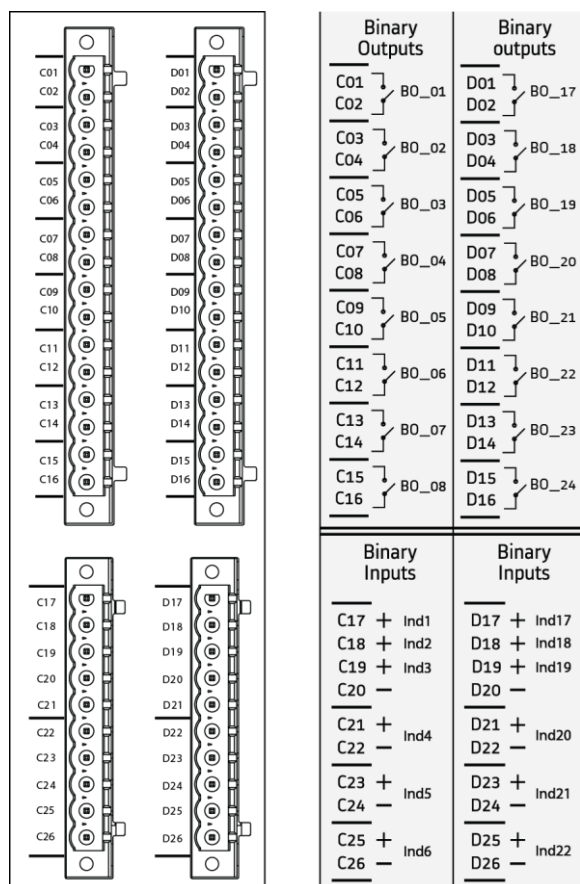

Binary inputs and outputs of the B2 board (8 BO + 6 BI)

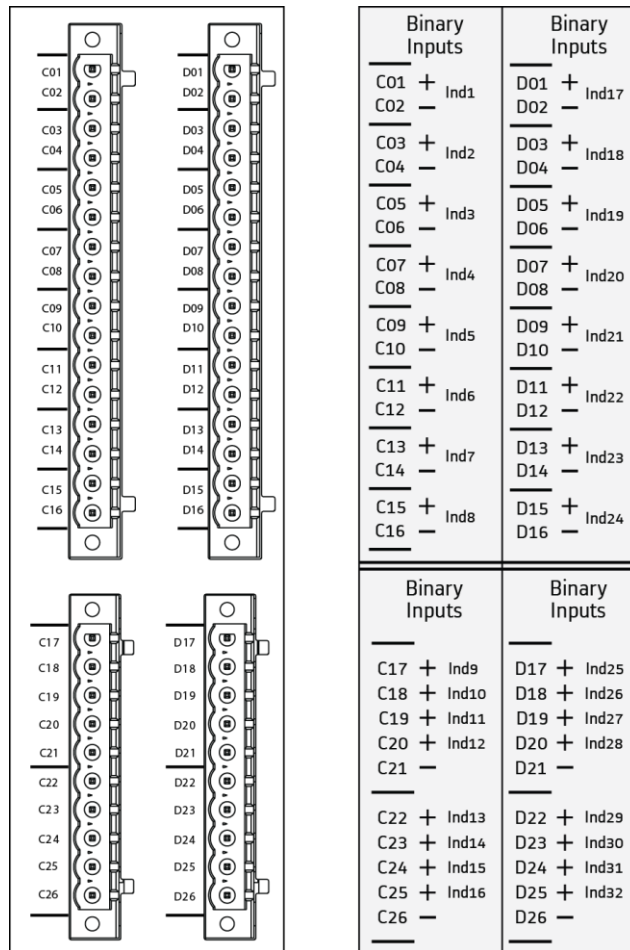

Binary inputs of the B1 board (16 Binary input)

4.8.1 Binary Inputs

The digital inputs can be used to obtain information from the power system, for example, the state of circuit breakers and other elements.

There are two options of binary input/output boards:

B1: 16 binary inputs and;

B2: 6 binary inputs (and 8 dry contact outputs)

All the binary inputs are optoisolated.

Note that, on the six-input slot, the first three inputs (terminals 17, 18 and 19 (of each module have a common negative indicated as '-' (terminal 20). On the 16-input board, BIs 09 to 12 (terminals 17 to 20) have a common negative and 13 to 16 (terminals 22 to 25) have another common negative.

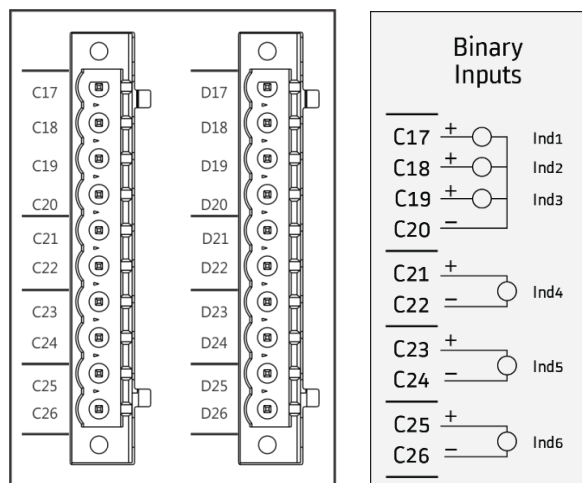

BI connectors diagram and terminal polarity of the B2 board (6 BI + 8 BO)

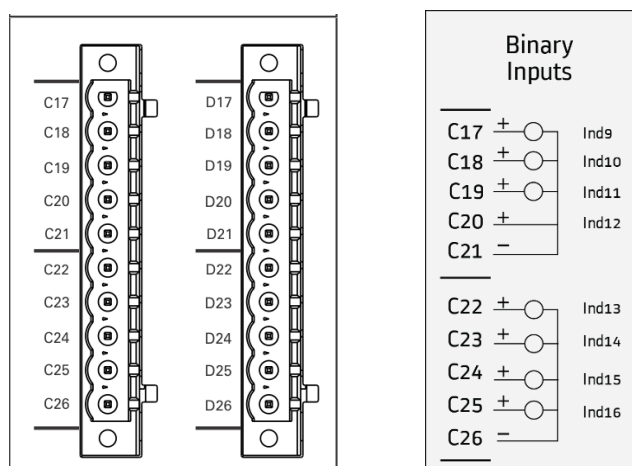

Connectors diagram and terminal polarity of the B1 board (16 BI) for terminals 17 to 26.

For information about the digital inputs specifications, refer to Technical Specifications Chapter.

The DR60 can work with up to 100% of its digital inputs and 50% of its digital outputs energized simultaneously at the maximum ambient temperature (considering the maximum number of inputs/output available).

Connections shall use screened/shielded cables with insulated flexible wires of 1.0 mm² cross section, voltage rating of 300Vrms.

4.8.2 Binary Outputs

The digital outputs can be used to control switching units (circuit breaker and recloser, for example) and announcements for remote signaling of events and status.

Each module has eight digital output channels. The digital outputs are shown in figure below.

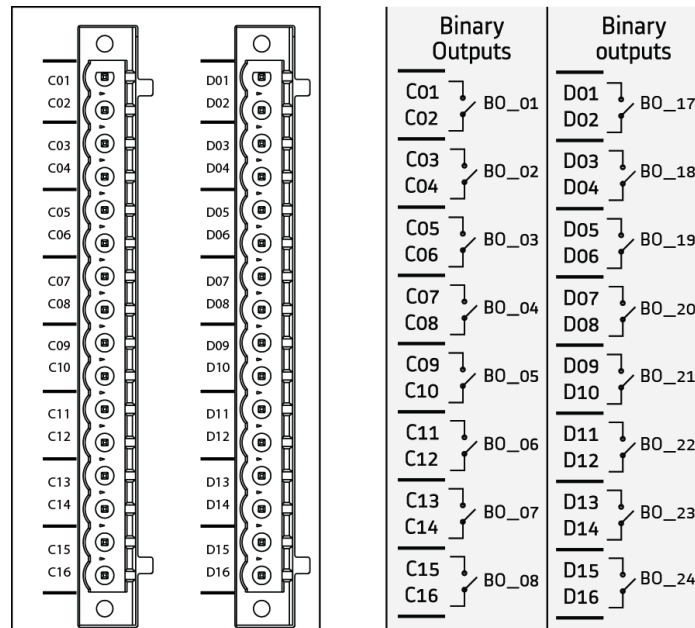

Digital outputs

For information about the digital outputs specifications, refer to Technical Specifications Chapter.

The DR60 can work with up to 100% of its digital inputs and 50% of its digital outputs energized simultaneously at the maximum ambient temperature (considering the maximum number of inputs/output available).

Connections shall use screened/shielded cables with insulated flexible wires of 1.0 mm² cross section, voltage rating of 300Vrms.

4.9 Voltage and Current Analog Inputs

Each analog slot (E and H) provides 4 AC/DC current inputs (1 or 5 A) and 4 AC/DC voltage inputs (115 V) or 4 DC transducer level voltage inputs ($\pm 10V$) and 4 DC-transducer level inputs (0-20mA).

All inputs are designated in DR60 software by their logical node name, as per IEC 61850 ed2. That means that the current inputs are names TCTR1 to TCTR16 and the voltage inputs names are TVTR1 to TVTR16. Additionally, the input name contains a prefix that associates the Slot the board is installed and the position of the input.

For example, the figure below shows the analog inputs designations from TCTR1 to 4 and TVTR1 to 4. In the DR Configurator tool, these inputs are named E1_TCTR1 to E4_TCTR4 and E5_TVTR1 to E8_TVTR4

The terminals in the position TVTR1, TVTR2 and TVTR3 share the same neutral, which is connected internally.

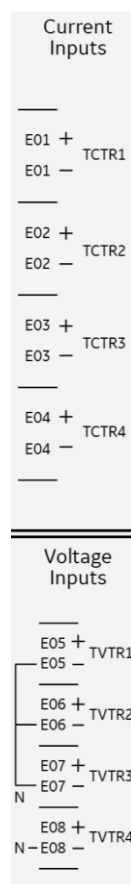

Voltage and current analog inputs

4.9.1 Current Analog Inputs

Each analog board of the DR60 has 4 current inputs. The inputs types are AC/DC 1A, AC/DC 5A, AC/DC 1A and 5A (high accuracy for metering) or DC transducer 0-20mA.

Before making the electrical connection, make sure the signal is applied in accordance with the technical specifications of the equipment.

For information about the analog current inputs specifications, refer to Technical Specifications Chapter.

Connections shall use screened/shielded cables with insulated flexible wires of at least 2.5 mm² cross section, 8 mm ring terminals, and M3 holes, voltage rating of 300Vrms.

4.9.2 Voltage Analog Inputs

Each analog board of the DR60 has 4 voltage inputs. The inputs types are AC/DC 115V (for protection), AC/DC 115V (high accuracy for metering) or DC transducer $\pm 10V$.

Before making the electrical connection, make sure the signal is applied in accordance with the technical specifications of the equipment.

For information about the analog current inputs specifications, refer to Technical Specifications Chapter.

Connections shall use screened/shielded cables with insulated flexible wires of 1.5 mm² cross section and 5.08 mm pitch plug terminals voltage rating of 300Vrms.

5 Case Dimensions

5.1 DR60 Dimensions and Weight

Dimensions of the equipment	
Height	222 mm / 8.7 in (5 U)
Width	222 mm / 8.7 in (½ 19")
Depth	121 mm / 4.7 in
Weight	< 3.5 kg (< 7.72 lb)

DR60 dimensions are shown on the figure below.

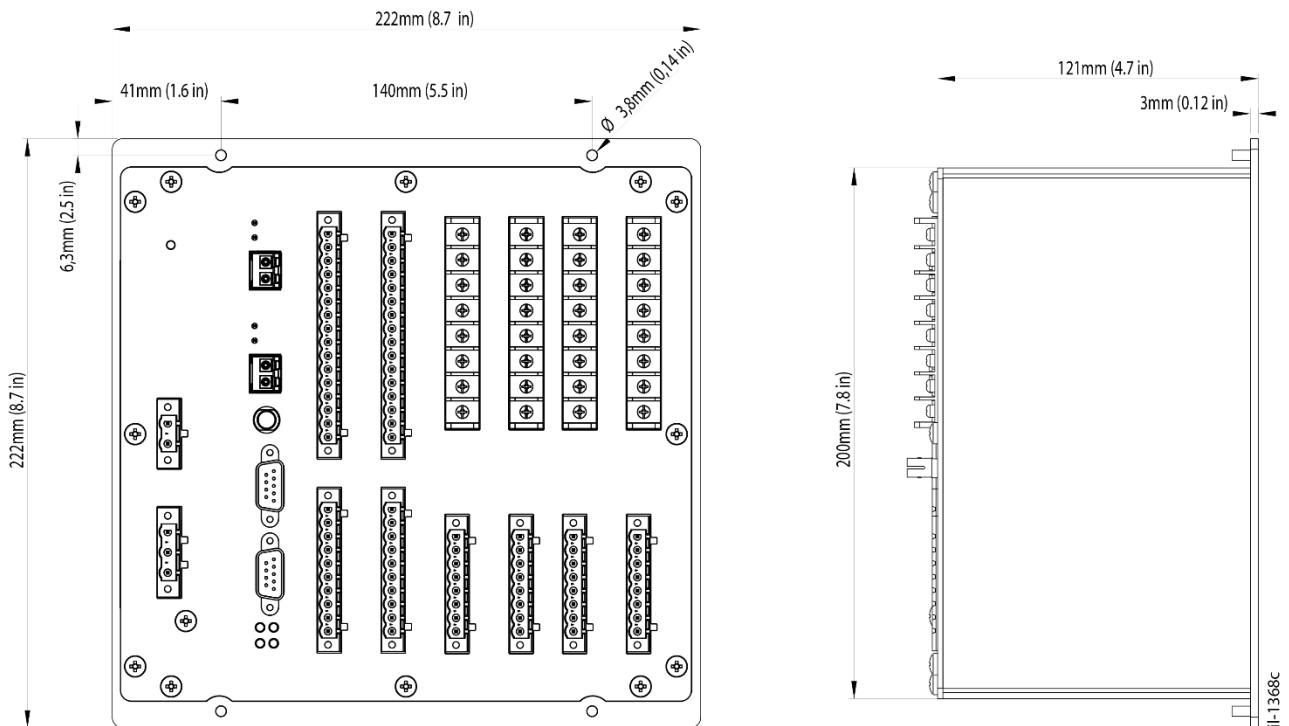

DR60 Dimensions

5.2 Panel Cutout

The DR60 panel cutout is shown in the figure below.

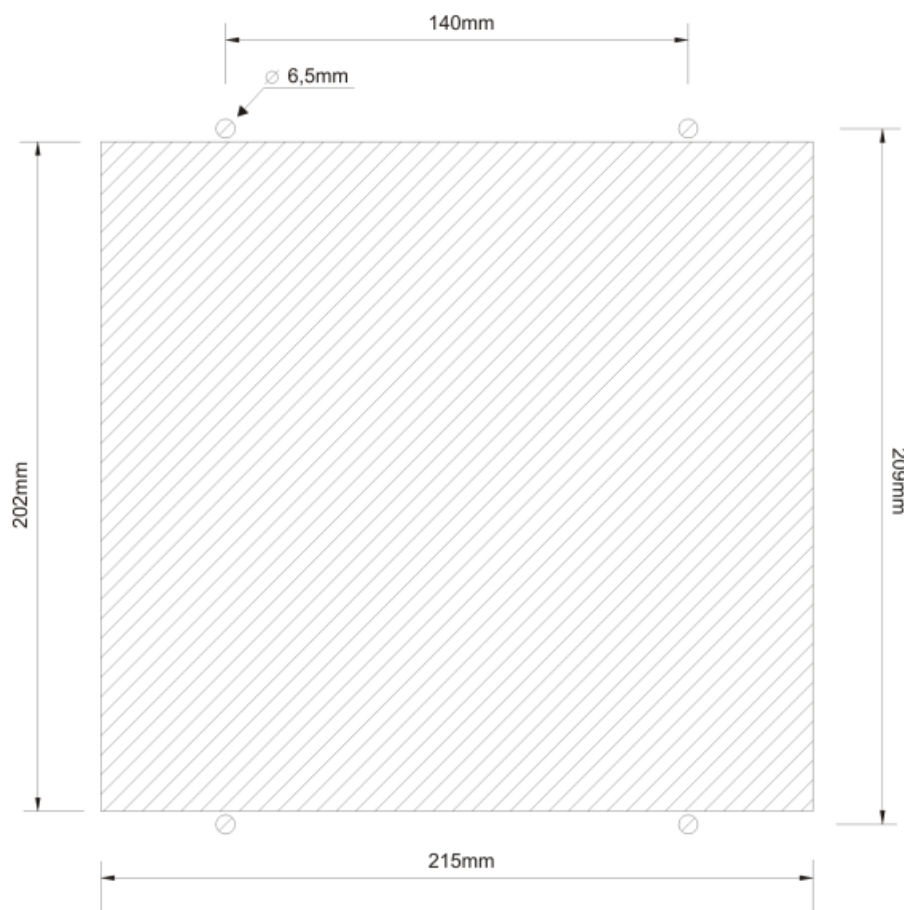

Panel cutout for DR60 installation

5.3 Accessories

DR60 accessories	
Q061	Mounting panel to install two DR60 in a 19-inch rack + blank plate to cover one cutout in case only one DR60 is being used.

5.3.2 Mounting Panel for Two DR60 (Q061)

Mounting Panel to install one/two DR60 in a 19-inch rack is shown in figure below. The mounting panel comes with a blank plate to cover one cutout in case only one DR60 is being used.

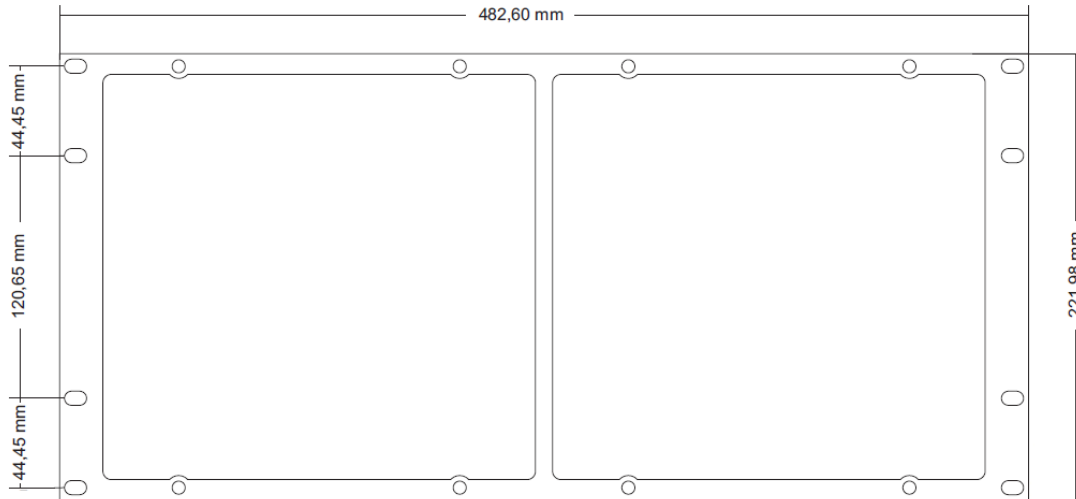

Double mounting chassis to install two DR60 in a 19-inch rack

6 DR60 Configurator Tools Installation

The DR60 Configuration Tool is the Windows based software responsible for device configuration, logs download and IED embedded software (firmware) upgrade.

6.1 Minimal requirements

The minimum hardware requirements supported by operational system and applications needed for the installation and implementation of the DR60 Configurator are described below.

Minimum hardware requirements:

- Processor 1 GHz or higher, 32-bit (x86) or 64-bit (x64);
- Minimum 1 GB RAM (32-bit) or 2 GB RAM (64-bit);
- Minimum 1 GB free space on disk;
- DirectX 9 or higher.

Supported operational system:

- Windows® XP 32-bit (x86) or 64-bit (x64).
- Windows® 7 32-bit (x86) or 64-bit (x64).

Applications:

- Microsoft dot.Net 4.0 version or higher;
- FTDI Driver 2.08.24 version or higher;

- Microsoft Visual C++ 2010 Redistributable Package (x86) SP1;
- Windows® Installer 3.1;
- Microsoft Visual C++ 2010 Redistributable Package (x86) (Must be installed even for x64 Windows®);
- Microsoft Visual C++ 2010 Redistributable Package (x64) (Must be installed only for x64 Windows®).

To install the DR60 Configurator, it is necessary be the system administrator. To verify if the user is the system administrator, access the Control Panel in Windows®, and go to Users Accounts.

DR60

Digital Recorder

Chapter 10: Maintenance

This chapter provides information about proper equipment maintenance and troubleshooting.

The troubleshooting part of the chapter allows an error condition on the IED to be identified so that appropriate corrective action can be taken.

1 Maintenance

1.1 Maintenance Checks

In view of the critical nature of the application, GE Grid products should be checked at regular intervals to confirm they are operating correctly.

The devices are self-supervising, most problems will result in an alarm, indicating that remedial action should be taken. However, some periodic tests should be carried out to ensure that they are functioning correctly and that the external wiring is intact. It is the responsibility of the customer to define the interval between maintenance periods. If your organization has a Preventative Maintenance Policy, the recommended product checks should be included in the regular program. Maintenance periods depend on many factors, such as:

- The operating environment
- The accessibility of the site
- The amount of available manpower
- The importance of the installation in the power system
- The consequences of failure

Although some functionality checks can be performed from a remote location, these are predominantly restricted to checking that the unit is measuring the applied currents and voltages accurately and checking the circuit breaker maintenance counters. For this reason, maintenance checks should also be performed locally at the substation.



Before carrying out any work on the equipment you should be familiar with the contents of the Safety Section and the ratings on the equipment's rating label.

While the DR60 performs continual self-tests, it is recommended that maintenance be scheduled with other system maintenance. This maintenance can involve in-service, out-of-service, or unscheduled maintenance.

1.1.1 In-service maintenance

1. Visual verification of the analog values integrity, such as voltage and current (in comparison to other devices on the corresponding system).
2. Visual verification of active alarms and LED indications.
3. Visual inspection for any damage, corrosion, dust, or loose wires.
4. Log file download with further events analysis.

1.1.2 Out-of-service maintenance

1. Check wiring connections for firmness.
2. Analog values (currents, voltages) injection test and metering accuracy verification. Calibrated test equipment is required.
3. Thresholds verification
4. Contact inputs and outputs verification. This test can be conducted by direct change of state forcing or as part of the system functional testing.
5. Visual inspection for any damage, corrosion, or dust.
6. Log file download for further events analysis.

1.1.3 Unscheduled maintenance (system interruption)

1. View the event recorder, logs and oscillography for correct operation of inputs, outputs, and elements

1.2 Backup and restore settings

Backup a copy of the in-service settings for each commissioned device, so as to revert to the commissioned settings after inadvertent, unauthorized, or temporary setting changes are made, after the settings defaulted due to firmware upgrade, or when the device has to be replaced. For information on how to download and upload configurations refer to the Configuration Chapter.

1.3 Measurement Accuracy

If the power system is energized, the measured values can be compared with known system values to check that they are in the expected range. If they are within a set range, this indicates that the A/D conversion and the calculations are being performed correctly. Alternatively, the measured values can be checked against known values injected into the device using the test block, (if fitted) or injected directly into the device's terminals.

1.4 Replacing the Unit

If your product should develop a fault while in service, depending on the nature of the fault, the watchdog contacts will change state and an alarm condition will be flagged. In the case of a fault, you should normally replace the cradle which slides easily out of the case. This can be done without disturbing the scheme wiring.

In the unlikely event that the problem lies with the wiring and/or terminals, then you must replace the complete device, rewire and re-commission the device.



If the repair is not performed by an approved service centre, the warranty will be invalidated.



Before carrying out any work on the equipment, you should be familiar with the contents of the Safety Information Chapter as well as the ratings on the equipment's rating label. This should ensure that no damage is caused by incorrect handling of the electronic components.



Before working at the rear of the unit, isolate all voltage and current supplying it.

1.5 Cleaning



Before cleaning the device, ensure that all AC and DC supplies and transformer connections are isolated, to prevent any chance of an electric shock while cleaning.

Only clean the equipment with a lint-free cloth dampened with clean water. Do not use detergents, solvents or abrasive cleaners as they may damage the product's surfaces and leave a conductive residue.

1.6 Watchdog

The DR60 presents an internal watchdog algorithm. This algorithm verifies, every second, if the device's system is responding correctly. Case the system does not respond the device performs a hardware reboot while the IN SERVICE relay signals that the DR60 is off.

2 DR60 Firmware Update

In DR60 product, depending on hardware compatibility described in each release notes, it is possible to update firmware through ethernet communication by using the administrative tools on DR60 Configurator tools.

After firmware version 02A05 all versions will be **digitally signed** from GE, ensuring that no malicious application can be installed in DR60 product.

For details on the firmware update procedure refer to the Configuration Chapter.

3 Procedure to reset password

In situations where the password is lost it is possible to execute the following the procedure:

1. Turn off the device
2. Connect an Ethernet electrical or fiber optic cable in between ethernet interfaces 1 and 2 creating a loopback connection
3. Turn on the device and wait for the complete startup
4. Turn off the device
5. Remove the loopback connection
6. Turn on the device, now passwords shall be the factory default

4 Equipment Return

All parts and components comprising Reason devices shall be repaired exclusively by GE. In case of equipment malfunction, the customer shall get in contact with GE Contact Centre and never attempt to repair the device by his own.

To request equipment repair service, call GE to check out shipment options and receive the technical assistance order code.

The equipment shall be packed in its original package or a suitable package to protect against impacts and moisture.

5 Instructions for Equipment Repair/Service for Service Personnel

The instructions presented in this topic shall only be followed by GE service Personnel. In case any repair needs to be done, follow the procedure below to ensure the safety of the operation.

1. Disconnect power supply;
2. Disconnect all other connections leaving the grounding strap to be removed at the end;
3. Perform a visual inspection to make sure the equipment is isolated;
4. Position the device in place where there is free space to work and make sure to install proper working and safety warnings at the location, also keep available all tools and aids that is going to be used;
5. Wait a few minutes so the capacitors may discharge;
6. Disassemble the device by unscrewing the case screws and pulling up the top side of the case; after that, carry on with the proper repairs. Keep in mind that disassembling the equipment may expose sensitive electronic circuitry. Take suitable precautions against electrostatic voltage discharge (ESD) to avoid damage to the equipment.

After the repairs are done, follow the procedure below in order to verify the safe state of the equipment and to put it back into operation.

1. Reconnect all internal cable that have been removed for the repair;
2. Perform a visual inspection on the device to make sure there are no remainders of the repair service inside the casing or any other non-compliance;
3. Place back the top side of the case and fasten it using the proper screws;
4. Connect the grounding strap and then the power supply to the equipment;

5. Wait for the equipment to initialize, it will run self-diagnostic routines and if everything is right the “Ready” LED on its front panel will light up indicating the equipment is safe and operational;
6. Follow the procedures in the Chapter 2 – Safety Information.

DR60

Digital Recorder

Chapter 11: Technical Specifications

This chapter describes the technical specifications of the product.

1 DR60 Specifications

1.1 Power Supply

Power Supply		
Operating nominal voltage	125-250 V dc, 110-240 V ac	24 – 48 Vdc
Maximum voltage range	100-300 V dc, 88-264 V ac	18 – 72 Vdc
Frequency	50 / 60 Hz, ± 3 Hz	---
Power consumption	60 VA @ 200mA	45W @ 700mA
Isolation Level	3.3 kVdc	3.3 kVdc

1.2 Ethernet Ports

Ethernet ports		
Type	Electrical	Optical
Use	Configuration, monitoring, communication, software upgrade, log download	Configuration, monitoring, communication, software upgrade, log download
Interface	10BASE-T / 100BASE-TX	100BASE-FX

Bit Rate	10 / 100 Mbps	100 Mbps
Connector	RJ 45	LC
Fiber type	---	Multimode 62,5/125µm
Wavelength	---	1300 nm
Emission power	---	-20 dBm
Sensitivity	---	-32dBm
Maximum applicable power	---	-14 dBm
Isolation Level	1.44 kVdc	---
Possible Redundancy	Failover	Failover

1.3 Optical IRIG-Input

Optical IRIG	
Signal	IRIG-B004
Wavelength	820 nm
Fiber type	Multimode 62.5 / 125 µm
Connector	ST
Sensitivity	- 24 dBm

1.4 Serial Ports

Serial Ports	
Interface	RS232

Use	Configuration, communication, software upgrade, log download
Bitrate	115200 bps
Data bits	7 or 8
Stop bits	1 or 2
Parity	None, even, odd
Connector	DB9 (female), standard DTE

1.5 Dry-contact Relay Outputs

IN SERVICE contact	
Description	Dry contact relay, normally closed
Switching Voltage	250 V (AC and DC)
Permissible current continuous	5 A
Maximum voltage	300 (AC and DC)
Making Capacity	15 A, 4 sec
Breaking Capacity	40W Resistive, 25 W/VA L/R = 50
Dropout time	< 5 ms
Burden	~50mA @12V [600mW]
Withstand voltages across open contacts	1000V rms
Permissible short time value for 1s	30A

1.6 Analog Acquisition

Analog Acquisition	
Resolution	16 bits
Frequency measurement range	15 Hz to 70 Hz
System Frequency	Bandwidth (frequency response)
50 Hz at 256 ppc	DC to 3,2 kHz
60 Hz at 256 ppc	DC to 3,8 kHz
50 Hz at 512 ppc	DC to 10 kHz
60 Hz at 512 ppc	DC to 10 kHz

1.7 Voltage Inputs

Voltage inputs specifications (50/60 Hz)		
Characteristic	Standard Input	High Accuracy Inputs
Nominal Voltage (V_n)	115 V	115V
Voltage range RMS	0.25-460 V	0.11-230 V
Analog Input Accuracy	Class 0.5 (IEC 61869-2) <0,1% of full scale	Class 0.1 (IEC 61869-2) <0,1% of full scale
Impedance	> 210 k Ω	> 420 k Ω
Burden V_n	< 0.1 VA	< 0.1 VA
Continuous Overload	230 V ($2 \times V_n$)	230 V ($2 \times V_n$)
Maximum Overload (1 s)	460 V ($4 \times V_n$)	460 V ($4 \times V_n$)
Input Isolation	>3,5 kV	>3,5 kV

1.8 Current Inputs

Current inputs (50/60Hz)			
Characteristic	Standard Input (P1)	Standard Input (P5)	High Accuracy Inputs (ME)
Nominal Current (I_n)	1 A	5 A	1 and 5 A
Current range	0.02... 40 A ($40I_n$)	0.1... 200 A ($40I_n$)	0.005... 10 A
Analog Input Accuracy	Class 0.5 (IEC 61869-2) ¹ 0,05In to 40In better than 0,1% of the measurement \pm 2mA <0,1% of full scale	Class 0.5 (IEC 61869-2) ¹ 0,05In to 0,2In better than 0,15% of the measurement \pm 5mA 0,2In to 0,5In better than 0,1% \pm 2mA of measurement 0,5In to 40In better than 0,1% of measurement <0,1% of full scale	Class 0.1 (IEC 61869-2) ¹ 0,05In to 40In better than 0,1% of the measurement \pm 1mA <0,1% of full scale
Resistance	7,5 m Ω	1,5 m Ω	15 m Ω
Burden I_n	< 0.02 VA	< 0.05 VA	< 0.02 VA
Continuous overload (rms)	4 A ($4 \times I_n$)	20 A ($4 \times I_n$)	10 A
AC current thermal withstand (I_{th} rms for 1 sec)	40 A ($40 \times I_n$)	200 A ($40 \times I_n$)	10 A
Input Isolation	>3,5 kV	>3,5 kV	>3,5 kV

¹ - Gauging performed using waveform measurement

1.9 DC Transducer Inputs

DC Transducer inputs specifications		
Characteristic	Voltage transducer input	Current transducer input
Measurement range	- 12,5 to + 12,5 V	0 to 25 mA
Accuracy	± 0.1 % of FS magnitude range	± 0,1 % of FS magnitude range
Impedance	> 5 kΩ	10 Ω

1.10 Binary Inputs

Binary Inputs		
Nominal Voltage (V_n)	125 / 250 V	24 / 48 V
Level low	65 V	8 V
Level High	91 V	13 V
Impedance	120 kΩ	14 kΩ
Burden V_n	< 0.14W@125V < 0.65W@250V	< 0.06W@24V < 0.18W@48V
Continuous Overload	300 V	100 V
Maximum Overload (1 s)	460 V (4 x V_n)	460 V (4 x V_n)
Acquisition sampling rate	256 and 512 spc	256 and 512 spc

1.11 Binary Outputs

Digital outputs specifications	
Description	Dry contact relay, normally open
Switching Voltage	250 V (AC and DC)

Maximum continuous current	3 A
Maximum voltage	300 (AC and DC)
Making Capacity	15 A, 4 sec
Breaking Capacity	40 W Resistive, 25 W/VA L/R = 50
Operation time	< 5 ms
Dropout time	< 15 ms
Burden	Per energized output relay: ~50mA @12V [600mW]
Withstand voltages across open contacts	1000V rms
Permissible short time value for 1s	30A

1.12 Environmental Conditions

Environmental Conditions	
Operating temperature range	- 40 ... +55 °C (−40°F to +131°F)
Maximum operating altitude	2000 m (6560 ft)
Relative humidity	5 ... 95 %, noncondensing
As tested per 60068-2-1	-40°C
As tested per 60068-2-2	+55°C
Enclosure Protection IEC 60529	IP20

1.13 Type Tests DR60

EMC tests were performed according to IEC 60255-26 referring to the following standards

Type Tests DR60

Test	Standard	Level
Electrostatic discharge	IEC 61000-4-2:2008	6kV contact / 8KV air (level 3)
RF immunity	IEC 61000-4-3:2006	10 V/m (level 3)
Fast transient disturbance	IEC 61000-4-4:2012	Zone A 4kV / 5kHz
Surge immunity	IEC 61000-4-5:2005	Zone A Differential mode: 2 kV Common mode: 4 kV
Conducted RF immunity	IEC 61000-4-6:2008	0.15MHz to 80MHz 10V/rms
Power magnetic immunity	IEC 61000-4-8:2009	30A/m continuous - 300A/m @ 1s (level 4)
Voltage dip, short interruptions and voltage variation immunity tests	IEC 61000-4-11:2004 IEC 61000-4-29:2000	<ul style="list-style-type: none"> ▪ AC and DC voltage dips Test level: 0% residual voltage Duration time a.c.: 1 cycle d.c.: 16.6ms ▪ Test level: 40% residual voltage Duration time a.c.: 12 cycle d.c.: 200ms ▪ Test level: 70% residual voltage Duration time a.c.: 30 cycle d.c.: 500ms ▪ AC and DC voltage interruptions Test level: 0% residual voltage Duration time a.c.: 300 cycles d.c.: 5s
Conducted RF immunity, 0 to 150 kHz	IEC 61000-4-16:2009	Zone A Test voltage Differential mode: 150 V rms Common mode: 300 V rms

Voltage ripple	IEC 61000-4-17:1999	Test level: 15 % of rated d.c. value Test frequency: 120Hz, sinusoidal waveform.
Damped oscillatory wave immunity test	IEC 61000-4-18:2006	Voltage oscillation frequency: 1MHz Differential mode: 1kV peak voltage; Common mode 2,5kV peak voltage
---	Gradual Startup	Shut-down ramp: 60s Power off: 5m Start-up ramp: 60s
Radio-frequency disturbance	CISPR11:2009	Radiated emission below 1GHz class A 30 MHz to 230 MHz 40 dB(μ V/m) quasi peak at 10 m 230 MHz to 1 000 MHz 47 dB(μ V/m) quasi peak at 10 m
Radio disturbance	CISPR22:2008	Radiated emission above 1GHz 1 GHz to 3 GHz 56 dB(μ V/m) Average 76 dB (μ V/m) peak at 3m 3 GHz to 6 GHz 60 dB(μ V/m) Average 80 dB (μ V/m) peak at 3m Conducted emission Class A 0,15 MHz to 0,50 MHz 79 dB(μ V) quasi peak 66 dB(μ V) average 0,5 MHz to 30 MHz 73 dB(μ V) quasi peak

60 dB(μ V) average

Note: If modules ME, P5 or P1 are used then *Fast transient disturbance* and *Surge Immunity* shall be considered zone B

1.14 Safety Tests

Safety tests	
Safety	IEC 60255-27:2014
IEC 60255-5	Impulse - 5KV Dielectric withstand - 3,3KVDC for 60 seconds Insulation > 100M Ω

1.15 Environmental tests

Environmental tests		
Cold	IEC 60068-2-1	-40°C, 16 hours
Dry heat	IEC 60068-2-2	+55°C, 16 hours
Damp heat	IEC 60068-2-78	95% no condensation, 55°C
Change of temperature	IEC 60068-2-14	-40°C to 55°C / 9 hours / 2 cycles
Vibration	IEC 60255-21-1	Class 2
Shock	IEC 60255-21-2	Class 1

1.16 Dimensions

Dimensions of the equipment	
Height	222 mm / 8.7 in (5 U)
Width	222 mm / 8.7 in (½ 19")
Depth	121 mm / 4.7 in
Weight	< 3.5 kg (< 7.72 lb)

DR60 dimensions are shown on the figure below.

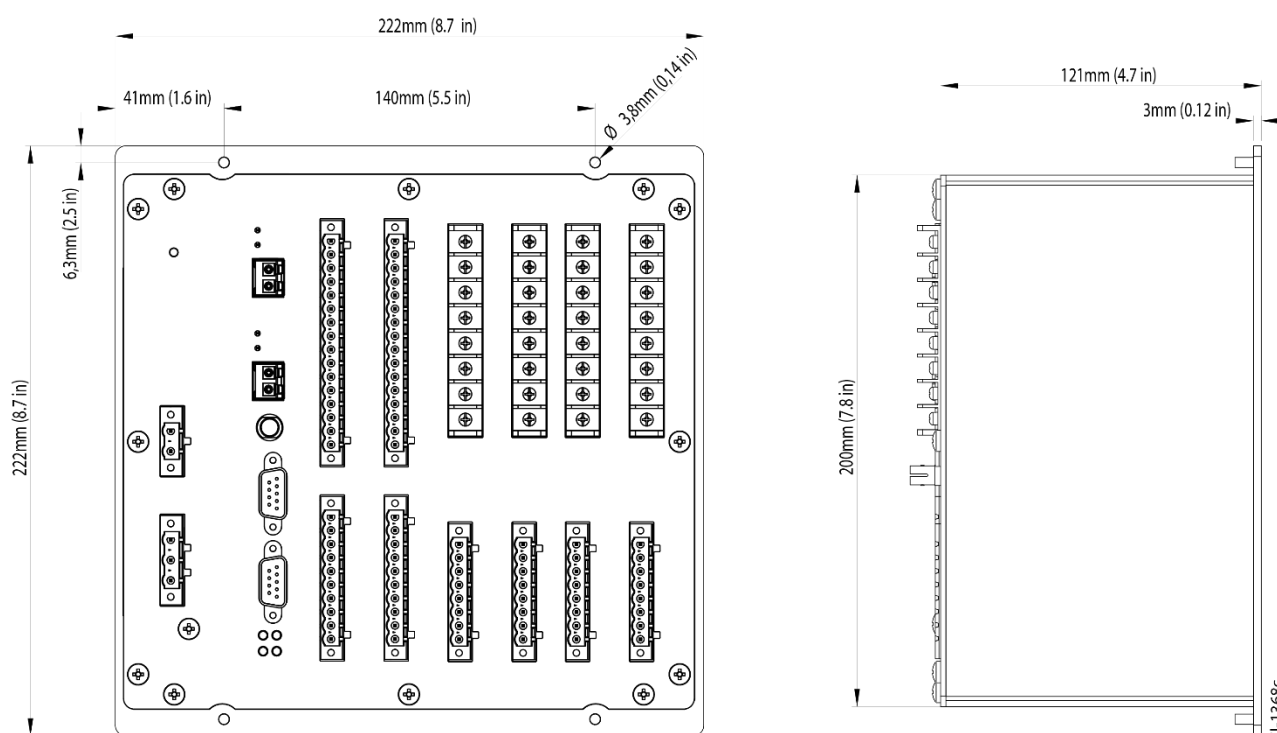

DR60 Dimensions

DR60

Digital Recorder

Chapter 12: Wiring Diagrams

This chapter contains the all the possible wiring diagrams for the analogue inputs. For further details on the inputs, refer to Installation Chapter

1 Connection Diagrams of the Voltage Inputs

The DR60 provides the capability for making some different voltage signal connections for a 3-phase circuit:

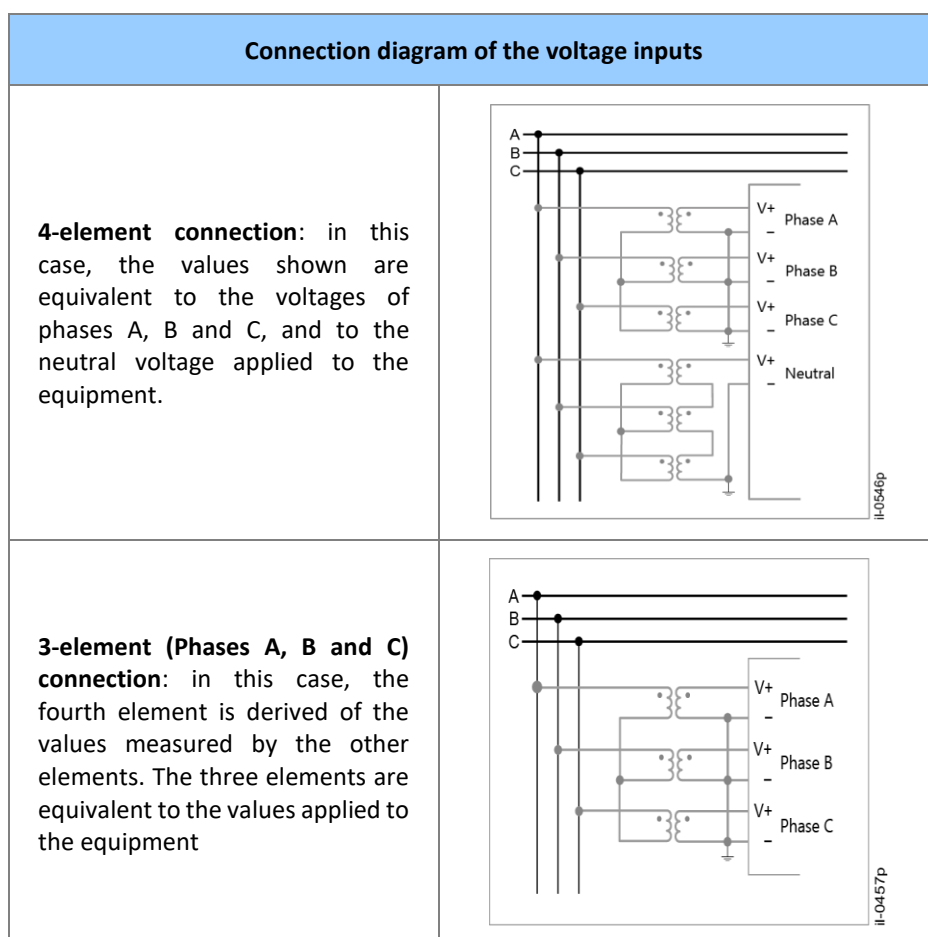

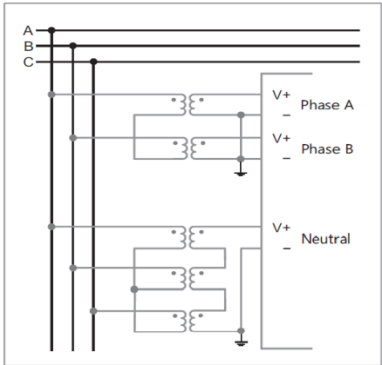
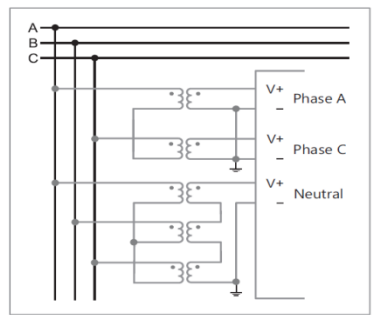
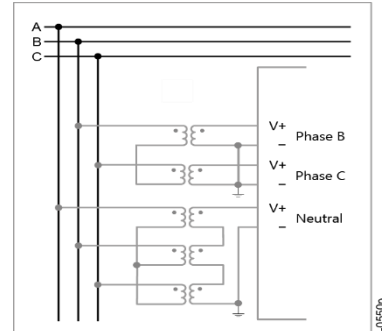
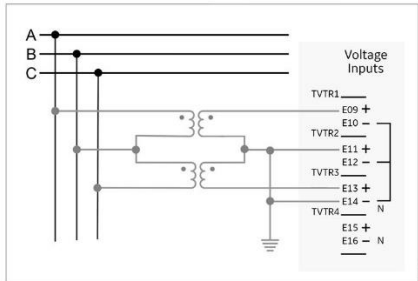
<p>3-element (Phases A, B and neutral) connection: in this case, the fourth element is synthesized of the values measured by the other elements. The three elements are equivalent to the values applied to the equipment.</p>	
<p>3-element (Phases A, C and neutral) connection: in this case, the fourth element is derived of the values measured by the other elements. The three elements are equivalent to the values applied to the equipment.</p>	
<p>3-element (Phases B, C and neutral) connection: in this case, the fourth element is derived of the values measured by the other elements. The three elements are equivalent to the values applied to the equipment.</p>	
<p>2-element connection: in this case, the neutral voltage is zero, and the three phase-to-ground voltage are computed based on the two line-to-line voltages applied to the equipment. For 2-element connection each circuit must be measured by the same analog module. Phase AB must be wired to the first voltage channel and CB wired to the third voltage channel of this module. The second channel is not used, but it can be wired like the picture.</p>	

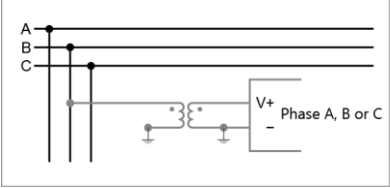
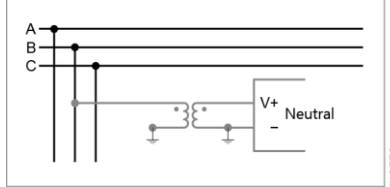
<p>1-element connection: Connection diagram of 1 element (phase A, B or C).</p>	 <p style="text-align: right;">il-0552p</p>
<p>1-element connection: Connection diagram of 1 element (neutral).</p>	 <p style="text-align: right;">il-0553p</p>

2 Connection Diagrams of the Current Inputs

The DR60 provides the capability for connecting some different current signal connections for a 3-phase circuit:

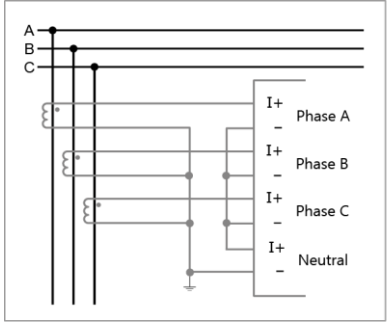
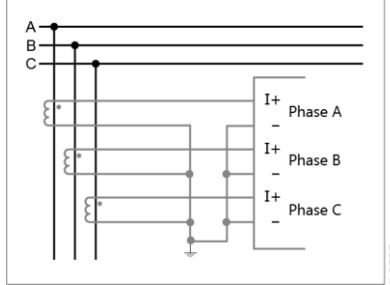
Connection diagram of the current inputs	
<p>4-element connection: in this case, the values shown are equivalent to the voltages of phases A, B and C, and to the neutral voltage applied to the equipment.</p>	 <p style="text-align: right;">il-0554p</p>
<p>3-element (Phases A, B and C) connection: in this case, the fourth element is derived of the values measured by the other elements. The three elements are equivalent to the values applied to the equipment.</p>	 <p style="text-align: right;">il-0555p</p>

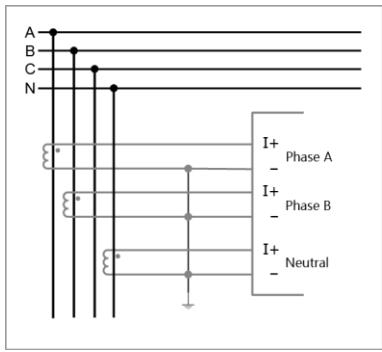
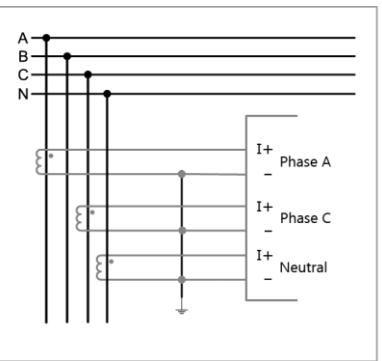
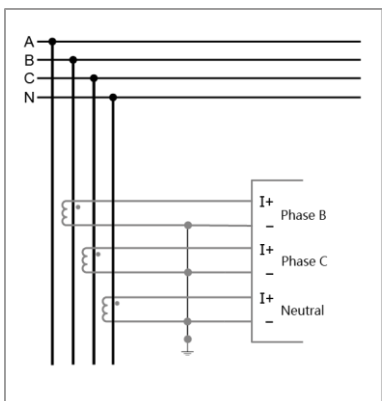
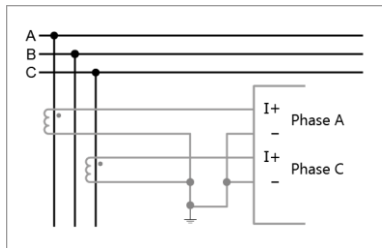
<p>3-element (Phases A, B and neutral) connection: in this case, the fourth element is derived of the values measured by the other elements. The three elements are equivalent to the values applied to the equipment.</p>	 <p style="text-align: right;">II-0556p</p>
<p>3-element (Phases A, C and neutral) connection: in this case, the fourth element is derived of the values measured by the other elements. The three elements are equivalent to the values applied to the equipment.</p>	 <p style="text-align: right;">II-0557p</p>
<p>3-element (Phases B, C and neutral) connection: in this case, the fourth element is derived of the values measured by the other elements. The three elements are equivalent to the values applied to the equipment.</p>	 <p style="text-align: right;">II-0558p</p>
<p>2-element connection: in this case, the neutral voltage is zero, and the three phase-to-ground voltage are computed based on the two line-to-line voltages applied to the equipment.</p>	 <p style="text-align: right;">II-0559p</p>

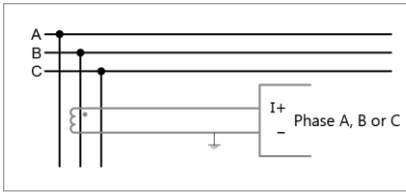
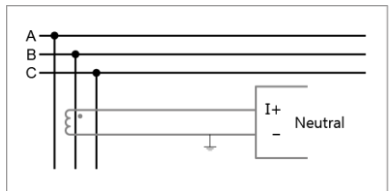
Connection diagram for 1 current element connection	
<p>1-element connection: Connection diagram of 1 element (phase A, B or C).</p>	 <p>II-0560P</p>
<p>1-element connection: Connection diagram of 1 element (neutral).</p>	 <p>II-0561P</p>

DR60

Digital Recorder

Appendix A – Equipment Log

1 Equipment Log

The equipment log contains information about:

- Threshold violations, fault and disturbance triggers and data recording;
- Data record transfer (including the IP address to which data has been transferred);
- Access to the unit's configuration pages (including IP address of which the access was performed);
- Alarms and the results of auto-diagnosis routines;
- Power-up and shutdown.

The equipment log cannot be erased by the user. Its capacity is enough for approximately 5 years of typical use, with past events being erased if memory space is needed.

Code	Message
LX01	First Install
LX02	Applied new settings to IED: <result>
LX03	Restored last valid settings
LX04	Downloaded settings from IED: <result>
LX05	Downloaded support file from IED: <result>
LX06	Downloaded user event logs from IED: <result>
LX07	Physical Health changed to <status> , cause: <cause>
LX08	Software upgraded from <value> to <value> : <result>
LX09	Applied new license to IED: <result>
LX10	Card failure: <cause> , slot <slot number>
LX11	Internal voltage: expected <value> V, measured <value> V, condition: <status>
LX12	Temperature: <value> °C, condition: <status>
LX13	Returned internal image to <value>
LX14	Power up
LC01	Ethernet link <status> , interface: <identifier>
LC02	Ethernet <identifier> settings changed to IP: <value> , submask: <value> , gateway: <value>
LC03	Serial <identifier> settings changed to speed: <value> bps, data bits: <value> , parity: <value> , stop bits: <value>

LC04	GOOSE Timeout: <identifier>
LC05	MMS Connection: <identifier>
LC06	Communication has been switched from port <inactive interface> to <active interface>
LL01	ST logic file isn't compatible with IED settings
LL02	Threshold <identifier> violated
LL03	Digital Threshold <identifier> violated
LS01	Synchronism changed to <status>, grandmaster: <value>, source: <value>
LS02	Synchronism quality changed to <status>
LS03	Timezone changed to UTC <hours>:<minutes>
LS04	Automatic daylight saving time programed for <status> at <date>
LS05	Daylight saving time started, new time set to <date>
LS06	Daylight saving time finished, new time set to <date>
LR01	Trigger recorder: <type>, re-trigger: <yes/no>
LR02	New record available, type: <type>
LR03	<type> recorder storage <status>
LR04	<type> recorder <status>, sample rate: <value>, re-trigger: <yes/no>
LR05	Erased old <number> records
LA01	System Frequency <number> Hz
LA02	No calibration for analog channel <channel>
LA03	No signal applied on analog channel <channel>
LB01	Binary inputs from all slots has been changed to <value>Vdc
LF01	Fault Locator <identifier>: Type <fault type>, distance <value>